



# Fender Application Design Manual

DESIGN MANUAL



# The Smarter Approach



## Connect with The Smarter Approach

By Trelleborg Marine and Infrastructure

-  Visit: [TrelleborgMarineandInfrastructure](#)
-  Connect: [trelleborg-marine-and-infrastructure](#)
-  Discover: [TrelleborgMarineandInfrastructure](#)
-  Converse: [@TrelleborgMI](#)
-  Explore: [marineandinfrastructure](#)
-  Discover: [TrelleborgMarineandInfrastructure](#)

**The demanding nature of commercial ports and terminals means you need partnership that provides much more than technically superior products and technologies. You need to work with a partner that combines best practice expertise gained through worldwide experience with a deep understanding of local requirements and regulations. At Trelleborg, we call this the Smarter Approach.**

Our Smarter Approach combines global reach with feet-on-the-ground local presence, delivering solutions that continually enhance your operations. Smart technologies are at the forefront of improving operational efficiencies. Trelleborg's innovative SmartPort offering deploys the latest in marine technology applications to help ports and terminals optimize their operations.

Connect with a partner that combines smart solutions, proven product capability and industry expertise to maintain and enhance port and vessel performance. Take a Smarter Approach, with Trelleborg Marine and Infrastructure.

# Fender Application Design Manual

**Trelleborg Marine and Infrastructure is a world leader in the design and manufacture of advanced marine fender systems.**

We provide bespoke solutions for large and complex projects all over the world. Best practice design and quality materials ensure a long, low maintenance service life, no matter how demanding the working and environmental conditions.

All fenders are supplied fully tested and meet PIANC 2002 guidelines. Our pneumatic fenders are also completely ISO17357-1:2014 compliant. Our high performance solutions combine low reaction force and hull pressure with good angular performance and rugged construction.

Trelleborg's fender systems can be integrated with SmartPort. SmartPort by Trelleborg is a technology platform that connects disparate, data-driven assets, giving stakeholders a holistic view of operations to power communication and decision making.

Take a Smarter Approach to fender performance with Trelleborg.



## Contents

### FENDER APPLICATION DESIGN MANUAL

INTRODUCTION	5
BERTHING ENVIRONMENT AND ENERGY CALCULATION	11
FENDER SELECTION & FENDER SYSTEMS DESIGN	29
FENDER ACCESSORIES	43
FENDER PERFORMANCE TESTING	53
OTHER DESIGN CONSIDERATIONS	61



# A Smarter Approach at every stage

A smarter approach to...

## CONSULTATION

Consultation from the earliest project phase to ensure the optimum fender systems and marine technology solutions are specified, with full technical support from our global offices.



## CONCEPT

Conceptual design in your local office – with full knowledge of local standards and regulations, delivered in your language – for optimized port and vessel solutions.



## DESIGN

Concepts are taken to our Engineering Centers of Excellence in India where our team generates 3D CAD designs, application-engineering drawings, a bill of materials, finite engineering analyses and calculations for both our fender systems and marine technology solutions.



## MANUFACTURE

Our entire product range is manufactured in-house, meaning we have full control over the design and quality of everything we produce. Our strategically located, state-of-the-art facilities ensure our global, industry leading manufacturing capability.



### TESTING

Across our entire product range, stringent testing comes as standard at every step in our in-house manufacturing process. We ensure that lifecycle and performance of our entire product range meets your specifications, and more.



### INSTALLATION

Dedicated project management, from solution design right the way through to on-site installation support. We design products and solutions that always consider ease of installation and future maintenance requirements.



### SUPPORT

Local support on a truly global scale, with customer support teams all over the world. And this service doesn't stop after a product is installed. You have our full support throughout the entire lifetime of your project, including customized training programs, maintenance and onsite service and support.



### THE FUTURE

Deploying the latest in smart technologies to enable fully automated, data-driven decision making that optimizes port and terminal efficiency. At Trelleborg, we're constantly evolving to provide the digital infrastructure our industry increasingly needs.



**When you choose Trelleborg you ensure your expectations will be met, because we deliver a truly end-to-end service – retaining vigilance and full control at every stage.**

# Introduction



Fender systems should be self-protective and reliably protect ships and structures. They should be long-lasting, requiring minimum maintenance, to withstand the harsh environment in which they operate.

As stated in the British Standard\*, fender design should be entrusted to 'appropriately qualified and experienced people'. Fender engineering requires an understanding of many areas:

- Ship technology
- Civil construction methods
- Steel fabrications
- Material properties
- Installation techniques
- Health and safety
- Environmental factors
- Regulations and codes of practice

\* BS6349 : – Code of Practice for Design of Fendering and Mooring Systems.

## USING THIS GUIDE

This guide addresses many of the frequently asked questions which arise during fender design. All methods described are based on the latest recommendations of PIANC as well as other internationally recognized codes of practice.

Methods are also adapted to working practices within Trelleborg and to suit Trelleborg products.

Further design tools and utilities including generic specifications, energy calculation spreadsheets, fender performance curves and much more can be requested from Trelleborg Marine and Infrastructure's local offices.

## EXCEPTIONS

These guidelines do not encompass unusual ships, extreme berthing conditions and other extreme cases for which specialist advice should be sought.

## DEFINITIONS

Rubber fender	Units made from vulcanized rubber (often with encapsulated steel plates) that absorbs energy by elastically deforming in compression, bending, shear or a combination of these effects.
Pneumatic fender	Units comprising fabric reinforced rubber bags filled with air under pressure and that absorbs energy from the work done in compressing the air above its normal initial pressure.
Foam fender	Units comprising a closed cell foam inner core with reinforced polymer outer skin that absorbs energy by virtue of the work done in compressing the foam.
Steel panel	A structural steel frame designed to distribute the forces generated during rubber fender compression.

## Why Fender?

'There is a simple reason to use fenders: it is just too expensive not to do so'. These are the opening remarks of PIANC and remain the primary reason why every modern port invests in protecting their structures with fender systems.

Well-designed fender systems will reduce construction costs and will contribute to making the berth more efficient by improving turn-around times. It follows that the longer a fender system lasts and the less maintenance it needs, the better the investment.

### 10 REASONS FOR QUALITY FENDERING

- Safety of staff, ships and structures
- Much lower lifecycle costs
- Rapid, trouble-free installation
- Quicker turnaround time, greater efficiency
- Reduced maintenance and repair
- Berths in more exposed locations
- Better ship stability when moored
- Lower structural loads
- Accommodate more ship types and sizes
- More satisfied customers

It is rare for the very cheapest fenders to offer the lowest long term cost. Quite the opposite is true. A small initial saving will often demand much greater investment in repairs and maintenance over the years. A cheap fender system can cost many times more than a well-engineered, higher quality solution over the lifetime of the berth as the graphs below demonstrate.

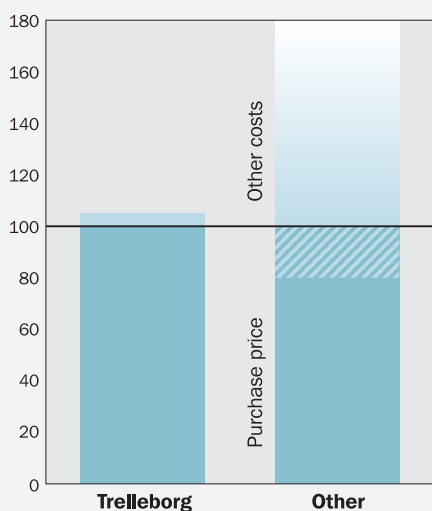

Purchase price  
 + Design approvals  
 + Delivery delays  
 + Installation time  
 + Site support  
 = **Capital cost**

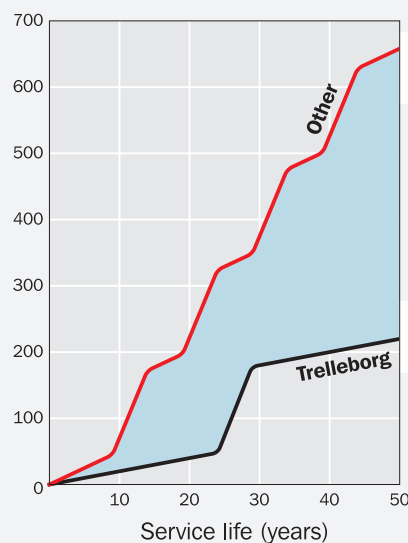

Wear & tear  
 + Replacements  
 + Damage repairs  
 + Removal & scrapping  
 + Fatigue, corrosion  
 = **Maintenance cost**

**Capital cost + Maintenance cost = FULL LIFE COST**



# Design Flowchart

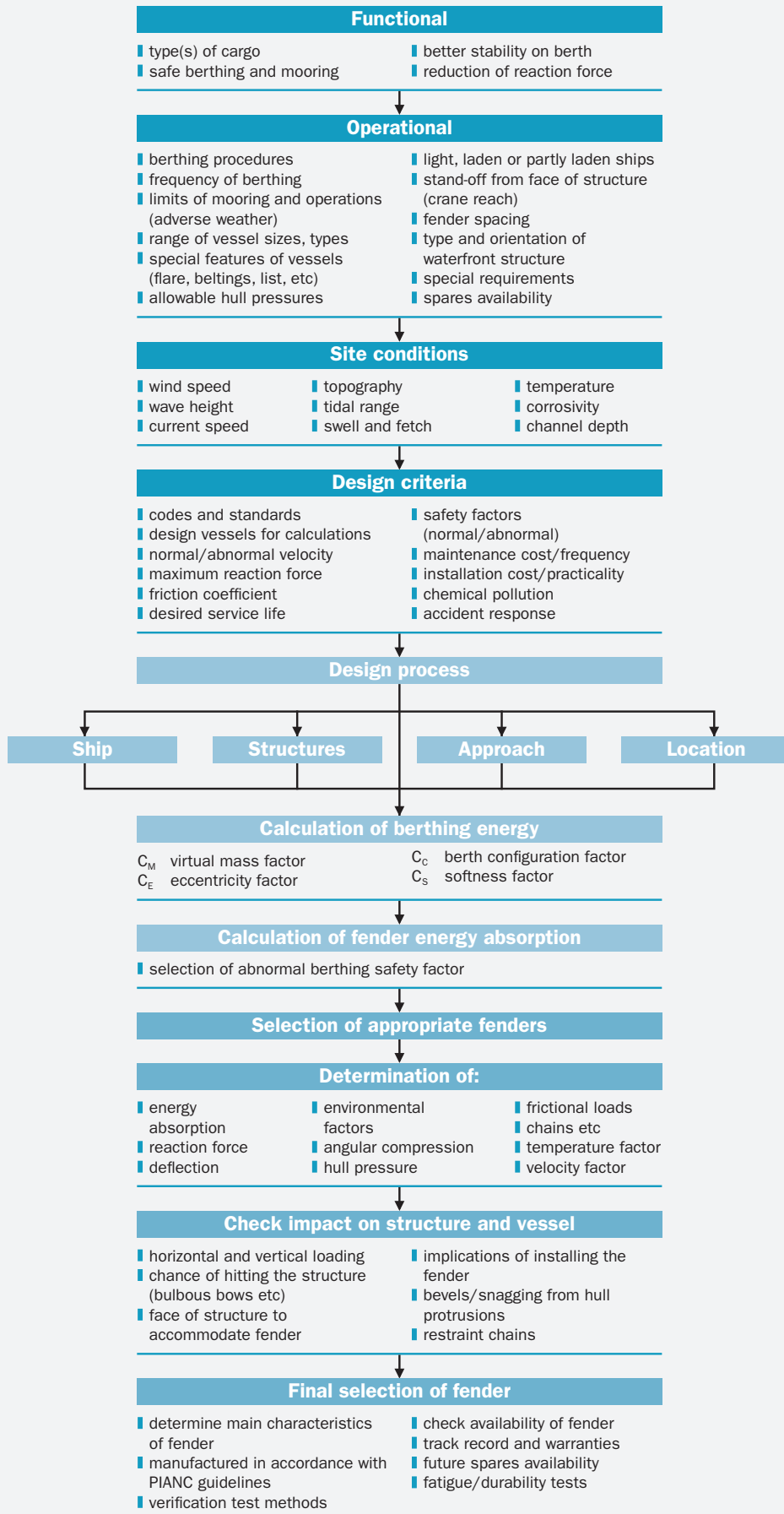

# The Design Process

Many factors contribute to the design of a fender system:

---

## SHIPS

Ship design evolves constantly – changes in shapes and increasing vessel sizes. Fender systems must suit current ships and those expected to arrive in the foreseeable future.



---

## STRUCTURES

Fenders impose loads on the berthing structure. Many berths are being built in exposed locations, where fender systems can play a crucial role in the overall cost of construction. Local practice, materials and conditions may influence the choice of fender systems.



---

## APPROACH

Many factors will affect how vessels approach the berth, the corresponding kinetic energy and the load applied to the structure. Berthing modes may affect the choice of ship's berthing speed and the safety factor for abnormal conditions.



---

## INSTALLATION AND MAINTENANCE

Fender systems installation should be considered early in the design process. Accessibility for maintenance, wear allowances and the protective coatings will all affect the full life cost of systems. Selecting the correct fenders can improve turnaround times and reduce downtime. The safety of personnel, structures and vessels must be considered at every stage – before, during and after commissioning.





# Berthing Environment & Energy calculation



We have a dedicated team who will provide a tailored solution for your project, on time and on budget.

As well as a full suite of engineering programs, we have expert designers who are experienced in all industry relevant CAD programs.

# Environment

## TYPICAL BERTHING LOCATIONS

Berthing structures are located in a variety of places from sheltered basins to unprotected, open waters. Local conditions will play a large part in

deciding the berthing speeds and approach angles, in turn affecting the type and size of suitable fenders.

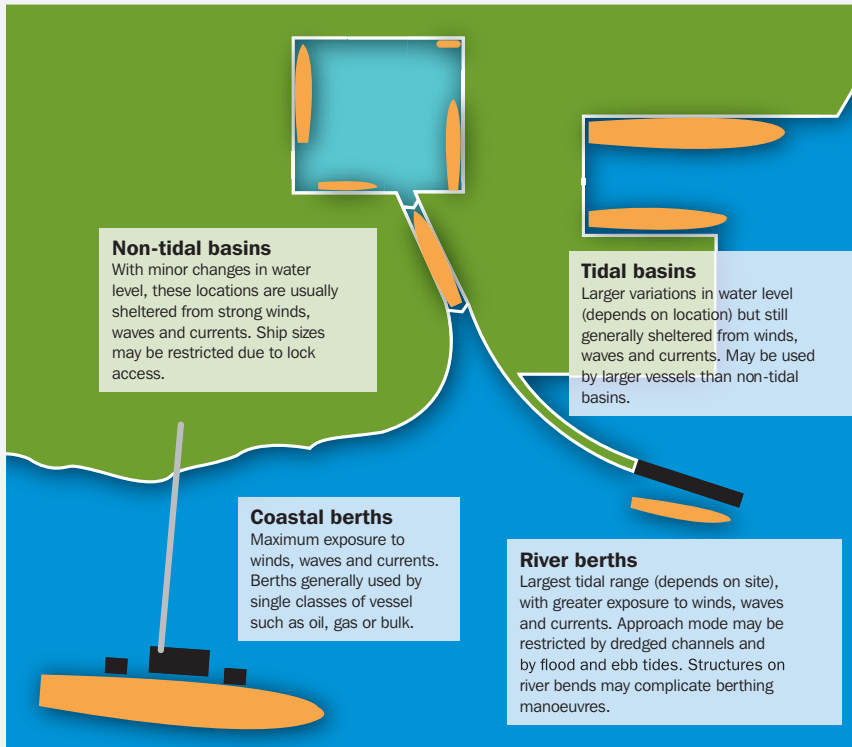

## CURRENTS AND WINDS

Current and wind forces can push vessels onto or off the berth, and may influence the berthing speed. Once berthed, and provided the vessel contacts several fenders, the forces are usually less critical. However special cases do exist, especially on very soft structures.

As a general guide, the probability of deep draught vessels (such as tankers) affected by current are higher and and likewise for high freeboard vessels (such as RoRo and container ships) affected by strong winds.







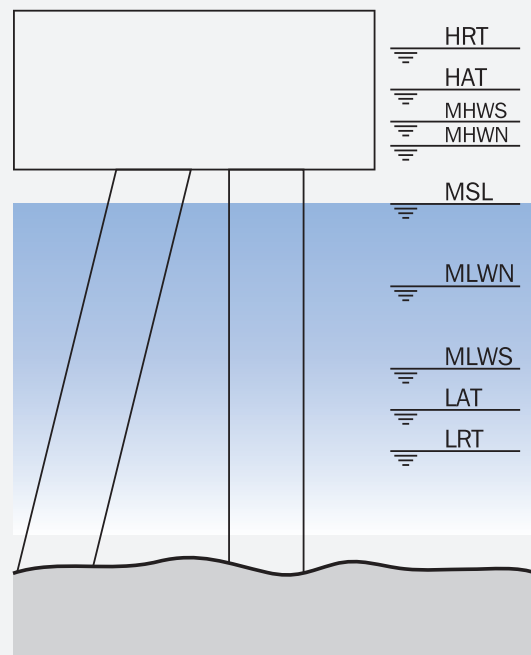

## TIDES

Tides vary by area and may have extremes of a few centimeters (Mediterranean, Baltic) or over 15 meters (parts of UK and Canada). Tides will influence the structure’s design and fender selection.















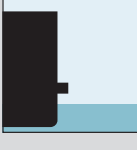

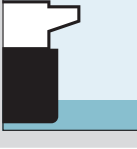

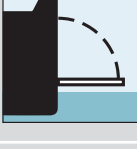

- HRT** Highest Recorded Tide
- HAT** Highest Astronomical Tide
- MHWS** Mean High Water Spring
- MHWN** Mean High Water Neap
- MLWN** Mean Low Water Neap
- MLWS** Mean Low Water Spring
- LAT** Lowest Astronomical Tide
- LRT** Lowest Recorded Tide

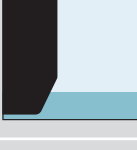

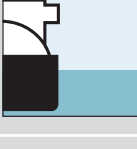
# Ship Types

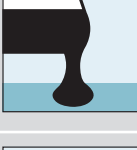
<p><b>General cargo ship</b></p> 	<ul style="list-style-type: none"> <li>  Prefer small gaps between ship and quay to minimize outreach of cranes</li> <li>  Large change of draft between laden and empty conditions</li> <li>  May occupy berths for long periods</li> <li>  Coastal cargo vessels may berth without tug assistance</li> </ul>
<p><b>Bulk carrier</b></p> 	<ul style="list-style-type: none"> <li>  Need to be close to berth face to minimize shiploader outreach</li> <li>  Possible need to warp ships along berth for shiploader to change holds</li> <li>  Large change of draft between laden and empty conditions</li> <li>  Require low hull contact pressures unless belted</li> </ul>
<p><b>Container ship</b></p> 	<ul style="list-style-type: none"> <li>  Flared bows are prone to strike shore structures</li> <li>  Increasing ship beams needs increased crane outreach</li> <li>  Some vessels have single or multiple beltings</li> <li>  Bulbous bows may strike front piles of structures at large berthing angles</li> <li>  Require low hull contact pressures unless belted</li> </ul>
<p><b>Oil tanker</b></p> 	<ul style="list-style-type: none"> <li>  Need to avoid fire hazards from sparks or friction</li> <li>  Large change of draft between laden and empty conditions</li> <li>  Require low hull contact pressures</li> <li>  Coastal tankers may berth without tug assistance</li> </ul>
<p><b>RoRo ship</b></p> 	<ul style="list-style-type: none"> <li>  Ships have own loading ramps – usually stern, slewed or side doors</li> <li>  High lateral and/or transverse berthing speeds</li> <li>  Manoeuvrability at low speeds may be poor</li> <li>  End berthing impacts often occur</li> <li>  Many different shapes, sizes and condition of beltings</li> </ul>
<p><b>Passenger (cruise) ship</b></p> 	<ul style="list-style-type: none"> <li>  Small draft change between laden and empty</li> <li>  White or light colored hulls are easily marked</li> <li>  Flared bows are prone to strike shore structures</li> <li>  Require low hull contact pressures unless belted</li> </ul>
<p><b>Ferry</b></p> 	<ul style="list-style-type: none"> <li>  Quick turn around needed</li> <li>  High berthing speeds, often with end berthing</li> <li>  Intensive use of berth</li> <li>  Berthing without tug assistance</li> <li>  Many different shapes, sizes and condition of beltings</li> </ul>
<p><b>Gas carrier</b></p> 	<ul style="list-style-type: none"> <li>  Need to avoid fire hazards from sparks or friction</li> <li>  Shallow draft even at full load</li> <li>  Require low hull contact pressures</li> <li>  Single class of vessels using dedicated facilities</li> <li>  Manifolds not necessarily at midships position</li> </ul>

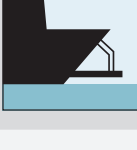
# Ship Features

<p><b>Bow flares</b></p>		<p>Common on container vessels and cruise ships. Big flare angles may affect fender performance. Larger fender may be required to maintain clearance from the quay structure, cranes, etc.</p>	
<p><b>Bulbous bows</b></p>		<p>Most modern ships have bulbous bows. Care is needed at large berthing angles or with widely spaced fenders to ensure the bulbous bow is not caught behind the fender or hit structural piles.</p>	
<p><b>Beltings &amp; strakes</b></p>		<p>Almost every class of ship could be fitted with beltings or strakes. They are most common on RoRo ships or ferries, but may even appear on container ships or gas carriers. Tugs and offshore supply boats have very large beltings.</p>	
<p><b>Flying bridge</b></p>		<p>Cruise and RoRo ships often have flying bridges. In locks, or when tides are large, care is needed to avoid the bridge sitting on top of the fender during a falling tide.</p>	
<p><b>Low freeboard</b></p>		<p>Barges, small tankers and general cargo ships can have a small freeboard. Fenders should be extended down to prevent being caught underneath during low tides when fully laden.</p>	
<p><b>Stern &amp; side doors</b></p>		<p>RoRo ships, car carriers and some navy vessels have large doors for vehicle access. These are often recessed and can snag fenders – especially in locks or when warping along the berth.</p>	
<p><b>High freeboard</b></p>		<p>Ships with high freeboard include ferries, cruise and container ships, as well as many lightly loaded vessels. Strong winds can cause sudden, large increases in berthing speeds.</p>	
<p><b>Low hull pressure</b></p>		<p>Many modern ships, but especially tankers and gas carriers, require very low hull contact pressures, which are achieved using large fender panels or floating fenders.</p>	
<p><b>Aluminium hulls</b></p>		<p>High speed catamarans and monohulls are often built from aluminium. They can only accept loads from fenders at special positions: usually reinforced beltings set very low or many meters above the waterline.</p>	
<p><b>Special features</b></p>		<p>Many ships are modified during their lifetime with little regard to the effect these changes may have on berthing or fenders. Protrusions can snag fenders but risks are reduced by large bevels and chamfers on the frontal panels.</p>	

# Ship Definitions

Many different definitions are used to describe ship sizes and classes. Some of the more common descriptions are given below. New ship

data (for example Triple E-Class) will be published when available.

VESSEL TYPE	LENGTH × BEAM × DRAFT	DWT	COMMENTS
Small feeder	200m × 23m × 9m	–	1st Generation container <1,000 teu
Feeder	215m × 30m × 10m	–	2nd Generation container 1,000–2,500 teu
Panamax <sup>1</sup>	290m × 32.3m × 12m	–	3rd Generation container 2,500–5,000 teu
Post-Panamax	305m × >32.3m × 13m	–	4th Generation container 5,000–8,000 teu
Super post-Panamax (VLCS)			5th Generation container >8,000 teu
Suezmax <sup>2</sup>	500m × 70m × 21.3m	–	All vessel types in Suez Canal
Seaway-Max <sup>3</sup>	233.5m × 24.0m × 9.1m	–	All vessel types in St Lawrence Seaway
Handysize	–	10,000–40,000 dwt	Bulk carrier
Cape Size	–	130,000–200,000 dwt	Bulk carrier
Very large bulk carrier (VLBC)	–	>200,000 dwt	Bulk carrier
Very large crude carrier (VLCC)	–	200,000–300,000 dwt	Oil tanker
Ultra large crude carrier (ULCC)	–	>300,000 dwt	Oil tanker

1. PANAMA CANAL	2. SUEZ CANAL	3. ST LAWRENCE SEAWAY
Lock chambers are 427m long and 55m wide. The deepest canal is 15.2m. The canal is about 86km long and passage takes eight hours.	The canal, connecting the Mediterranean and Red Sea, is about 163km long and varies from 80–135m wide. It has no lock chambers but most of the canal has a single traffic lane with passing bays.	The seaway system allows ships to pass from the Atlantic Ocean to the Great Lakes via six short canals totalling 110km, with 19 locks, each 233m long, 24.4m wide and 9.1m deep.

Note: Dimensions based on the new Panama locks that will be opened in 2016. Current dimensions are 305 m long, 33.5 m wide, largest depth is 12.5 – 13.7 m.

The ship tables show laden draft ( $D_L$ ) of vessels. The draft of a partly loaded ship ( $D$ ) can be estimated using the formula below:

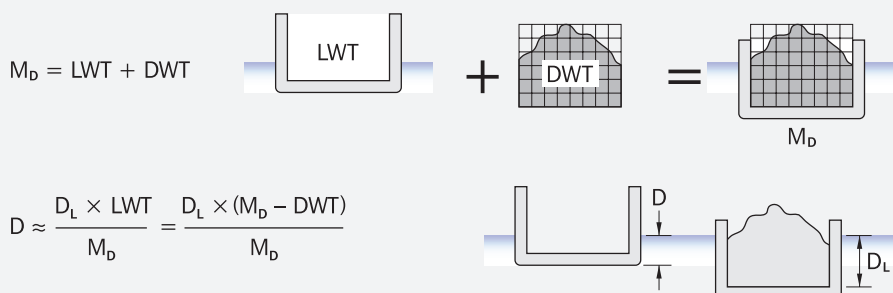

## USING SHIP TABLES

PIANC’s report from working group 121 “Harbor approach channels design guidelines” was released in 2014. This report contains very useful tables with design information on vessels. These data can be considered as the latest available design information, replacing PIANC 2002 at this point. The tables in the Trelleborg Marine and Infrastructure design manual are taken from PIANC

report WG121 table C-1 and these originate from the Spanish ROM 3.1. Additional information on vessels sizes can be found in PIANC report W121 table C-2 and C-3, PIANC 2002 and EAU 2004 and the Spanish ROM 2.0-11.

Newer generation ships will continue to come in line, please ask Trelleborg Marine and Infrastructure for supplementary tables or latest and largest types.



# Ship Tables

TYPE	DWT (t)	DISPLACEMENT (t)	L <sub>OA</sub> (m)	L <sub>BP</sub> (m)	B (m)	LADEN DRAFT (m)	C <sub>B</sub> (-)	MIN. LATERAL WINDAGE: FULLY LOADED (m <sup>2</sup> )	MAX. LATERAL WINDAGE: IN BALLAST (m <sup>2</sup> )	APPROX. CAPACITY (m <sup>3</sup> )
Tankers (ULCC)	500,000	590,000	415.0	392.0	73.0	24.0	0.84	6,400	11,000	–
	400,000	475,000	380.0	358.0	68.0	23.0	0.83	5,700	9,700	–
	350,000	420,000	365.0	345.0	65.5	22.0	0.82	5,400	9,200	–
Tankers (VLCC)	300,000	365,000	350.0	330.0	63.0	21.0	0.82	5,100	8,600	–
	275,000	335,000	340.0	321.0	61.0	20.5	0.81	4,900	8,200	–
	250,000	305,000	330.0	312.0	59.0	19.9	0.81	4,600	7,700	–
	225,000	277,000	320.0	303.0	57.0	19.3	0.81	4,300	7,300	–
	200,000	246,000	310.0	294.0	55.0	18.5	0.80	4,000	6,800	–
Tankers	175,000	217,000	300.0	285.0	52.5	17.7	0.80	3,750	6,200	–
	150,000	186,000	285.0	270.0	49.5	16.9	0.80	3,400	5,700	–
	125,000	156,000	270.0	255.0	46.5	16.0	0.80	3,100	5,100	–
	100,000	125,000	250.0	236.0	43.0	15.1	0.80	2,750	4,500	–
	80,000	102,000	235.0	223.0	40.0	14.0	0.80	2,450	4,000	–
	70,000	90,000	225.0	213.0	38.0	13.5	0.80	2,250	3,700	–
	60,000	78,000	217.0	206.0	36.0	13.0	0.79	2,150	3,500	–
Product and Chemical Tankers	50,000	66,000	210.0	200.0	32.2	12.6	0.79	1,900	3,000	–
	40,000	54,000	200.0	190.0	30.0	11.8	0.78	1,650	2,600	–
	30,000	42,000	188.0	178.0	28.0	10.8	0.76	1,400	2,200	–
	20,000	29,000	174.0	165.0	24.5	9.8	0.71	1,100	1,800	–
	10,000	15,000	145.0	137.0	19.0	7.8	0.72	760	1,200	–
	5,000	8,000	110.0	104.0	15.0	7.0	0.71	500	800	–
	3,000	4,900	90.0	85.0	13.0	6.0	0.72	400	600	–
Bulk Carriers / OBO's	400,000	464,000	375.0	356.0	62.5	24.0	0.85	4,500	8,700	–
	350,000	406,000	362.0	344.0	59.0	23.0	0.85	4,400	8,500	–
	300,000	350,000	350.0	333.0	56.0	21.8	0.84	4,250	8,200	–
	250,000	292,000	335.0	318.0	52.5	20.5	0.83	4,000	7,700	–
	200,000	236,000	315.0	300.0	48.5	19.0	0.83	3,600	6,900	–
	150,000	179,000	290.0	276.0	44.0	17.5	0.82	3,250	5,900	–
	125,000	150,000	275.0	262.0	41.5	16.5	0.82	3,000	5,400	–
	100,000	121,000	255.0	242.0	39.0	15.3	0.82	2,700	4,800	–
	80,000	98,000	240.0	228.0	36.5	14.0	0.82	2,450	4,200	–
	60,000	74,000	220.0	210.0	33.5	12.8	0.80	2,050	3,500	–
	40,000	50,000	195.0	185.0	29.0	11.5	0.79	1,700	2,800	–
	20,000	26,000	160.0	152.0	23.5	9.3	0.76	1,400	2,300	–
10,000	13,000	130.0	124.0	18.0	7.5	0.76	1,200	1,800	–	
LNG Carriers (Prismatic)	125,000	175,000	345.0	333.0	55.0	12.0	0.78	8,400	9,300	267,000
	97,000	141,000	315.0	303.0	50.0	12.0	0.76	7,000	7,700	218,000
	90,000	120,000	298.0	285.0	46.0	11.8	0.76	6,200	6,800	177,000
	80,000	100,000	280.0	268.8	43.4	11.4	0.73	6,000	6,500	140,000
	52,000	58,000	247.3	231.0	34.8	9.5	0.74	4,150	4,600	75,000
	27,000	40,000	207.8	196.0	29.3	9.2	0.74	2,900	3,300	40,000

Note: Dimensions given in tables may vary up to ±10% depending on construction and country of origin (this note comes from the origin document WG121)

# Ship Tables

TYPE	DWT (t)	DISPLACEMENT (t)	L <sub>OA</sub> (m)	L <sub>PP</sub> (m)	B (m)	LADEN DRAFT (m)	C <sub>B</sub> (-)	MIN. LATERAL WINDAGE: FULLY LOADED (m <sup>2</sup> )	MAX. LATERAL WINDAGE: IN BALLAST (m <sup>2</sup> )	APPROX. CAPACITY (m <sup>3</sup> )
LNG Carriers (Spheres, Moss)	75,000	117,000	288.0	274.0	49.0	11.5	0.74	8,300	8,800	145,000
	58,000	99,000	274.0	262.0	42.0	11.3	0.78	7,550	8,000	125,000
	51,000	71,000	249.5	237.0	40.0	10.6	0.69	5,650	6,000	90,000
LPG Carriers	60,000	95,000	265.0	245.0	42.2	13.5	0.66	5,600	6,200	–
	50,000	80,000	248.0	238.0	39.0	12.9	0.65	5,250	5,800	–
	40,000	65,000	240.0	230.0	35.2	12.3	0.64	4,600	5,100	–
	30,000	49,000	226.0	216.0	32.4	11.2	0.61	4,150	4,600	–
	20,000	33,000	207.0	197.0	26.8	10.6	0.58	3,500	3,900	–
	10,000	17,000	160.0	152.0	21.1	9.3	0.56	2,150	2,500	–
	5,000	8,800	134.0	126.0	16.0	8.1	0.53	1,500	1,700	–
3,000	5,500	116.0	110.0	13.3	7.0	0.52	1,050	1,200	–	

TYPE	DWT (t)	DISPLACEMENT (t)	L <sub>OA</sub> (m)	L <sub>PP</sub> (m)	B (m)	LADEN DRAFT (m)	C <sub>B</sub> (-)	MIN. LATERAL WINDAGE: FULLY LOADED (m <sup>2</sup> )	MAX. LATERAL WINDAGE: IN BALLAST (m <sup>2</sup> )	APPROX. CAPACITY: TEU / CEU
Container Ships (Post-Panamax)	245,000	340,000	470.0	446.0	60.0	18.0	0.69	11,000	12,500	22,000
	200,000	260,000	400.0	385.0	59.0	16.5	0.68	10,700	12,000	18,000
	195,000	250,000	418.0	395.0	56.4	16.0	0.68	10,100	11,300	14,500
	165,000	215,000	398.0	376.0	56.4	15.0	0.66	9,500	10,500	12,200
	125,000	174,000	370.0	351.0	45.8	15.0	0.70	8,700	9,500	10,000
	120,000	158,000	352.0	335.0	45.6	14.8	0.68	8,000	8,700	9,000
	110,000	145,000	340.0	323.0	43.2	14.5	0.70	7,200	7,800	8,000
	100,000	140,000	326.0	310.0	42.8	14.5	0.71	6,900	7,500	7,500
	90,000	126,000	313.0	298.0	42.8	14.5	0.66	6,500	7,000	7,000
	80,000	112,000	300.0	284.0	40.3	14.5	0.66	6,100	6,500	6,500
	70,000	100,000	280.0	266.0	41.8	13.8	0.64	5,800	6,100	6,000
	65,000	92,000	274.0	260.0	41.2	13.5	0.62	5,500	5,800	5,600
	60,000	84,000	268.0	255.0	39.8	13.2	0.61	5,400	5,700	5,200
	55,000	76,500	261.0	248.0	38.3	12.8	0.61	5,200	5,500	4,800
Container Ships (Panamax)	60,000	83,000	290.0	275.0	32.2	13.2	0.69	5,300	5,500	5,000
	55,000	75,500	278.0	264.0	32.2	12.8	0.68	4,900	5,100	4,500
	50,000	68,000	267.0	253.0	32.2	12.5	0.65	4,500	4,700	4,000
	45,000	61,000	255.0	242.0	32.2	12.2	0.63	4,150	4,300	3,500
	40,000	54,000	237.0	225.0	32.2	11.7	0.62	3,750	3,900	3,000
	35,000	47,500	222.0	211.0	32.2	11.1	0.61	3,550	3,700	2,600
	30,000	40,500	210.0	200.0	30.0	10.7	0.62	3,350	3,500	2,200
	25,000	33,500	195.0	185.0	28.5	10.1	0.61	2,900	3,000	1,800
	20,000	27,000	174.0	165.0	26.2	9.2	0.66	2,400	2,500	1,500
	15,000	20,000	152.0	144.0	23.7	8.5	0.67	2,000	2,100	1,100
10,000	13,500	130.0	124.0	21.2	7.3	0.69	1,800	1,900	750	

Note: Dimensions given in tables may vary up to ±10% depending on construction and country of origin (this note comes from the origin document WG121)

# Ship Tables

TYPE	DWT (t)	DISPLACEMENT (t)	L <sub>OA</sub> (m)	L <sub>pp</sub> (m)	B (m)	LADEN DRAFT (m)	C <sub>B</sub> (-)	MIN. LATERAL WINDAGE: FULLY LOADED (m <sup>2</sup> )	MAX. LATERAL WINDAGE: IN BALLAST (m <sup>2</sup> )	APPROX. CAPACITY: TEU / CEU
Freight RoRo Ships	50,000	87,500	287.0	273.0	32.2	12.4	0.78	7,500	7,800	5,000
	45,000	81,500	275.0	261.0	32.2	12.0	0.79	6,850	7,100	4,500
	40,000	72,000	260.0	247.0	32.2	11.4	0.77	6,200	6,400	4,000
	35,000	63,000	245.0	233.0	32.2	10.8	0.76	5,600	5,800	3,500
	30,000	54,000	231.0	219.0	32.0	10.2	0.74	5,100	5,300	3,000
	25,000	45,000	216.0	205.0	31.0	9.6	0.72	4,600	4,800	2,500
	20,000	36,000	197.0	187.0	28.6	9.1	0.72	4,250	4,400	2,000
	15,000	27,500	177.0	168.0	26.2	8.4	0.73	3,750	3,900	1,500
	10,000	18,400	153.0	145.0	23.4	7.4	0.71	3,100	3,200	1,000
	5,000	9,500	121.0	115.0	19.3	6.0	0.70	2,200	2,300	600
Cargo Vessels	40,000	54,500	209.0	199.0	30.0	12.5	0.71	3,250	4,500	-
	35,000	48,000	199.0	189.0	28.9	12.0	0.71	3,000	4,100	-
	30,000	41,000	188.0	179.0	27.7	11.3	0.71	2,700	3,700	-
	25,000	34,500	178.0	169.0	26.4	10.7	0.71	2,360	3,200	-
	20,000	28,000	166.0	158.0	24.8	10.0	0.70	2,100	2,800	-
	15,000	21,500	152.0	145.0	22.6	9.2	0.70	1,770	2,400	-
	10,000	14,500	133.0	127.0	19.8	8.0	0.70	1,380	1,800	-
	5,000	7,500	105.0	100.0	15.8	6.4	0.72	900	1,200	-
	2,500	4,000	85.0	80.0	13.0	5.0	0.75	620	800	-
Car Carriers	70,000	52,000	228.0	210.0	32.2	11.3	0.66	5,700	6,900	8,000
	65,000	48,000	220.0	205.0	32.2	11.0	0.64	5,400	6,500	7,000
	57,000	42,000	205.0	189.0	32.2	10.9	0.62	4,850	5,800	6,000
	45,000	35,500	198.0	182.0	32.2	10.0	0.59	4,300	5,100	5,000
	36,000	28,500	190.0	175.0	32.2	9.0	0.55	3,850	4,600	4,000
	27,000	22,000	175.0	167.0	28.0	8.4	0.55	3,400	4,000	3,000
	18,000	13,500	150.0	143.0	22.7	7.4	0.55	2,600	3,000	2,000
	13,000	8,000	130.0	124.0	18.8	6.2	0.54	2,000	2,200	1,000
	8,000	4,300	100.0	95.0	17.0	4.9	0.53	1,300	1,400	700
Ferries	50,000	82,500	309.0	291.0	41.6	10.3	0.65	6,150	6,500	-
	40,000	66,800	281.0	264.0	39.0	9.8	0.65	5,200	5,500	-
	30,000	50,300	253.0	237.0	36.4	8.8	0.65	4,300	4,500	-
	20,000	33,800	219.0	204.0	32.8	7.8	0.63	3,300	3,500	-
	15,000	25,000	197.0	183.0	30.6	7.1	0.61	2,650	2,800	-
	12,500	21,000	187.0	174.0	28.7	6.7	0.61	2,450	2,600	-
	11,500	19,000	182.0	169.0	27.6	6.5	0.61	2,350	2,500	-
	10,200	17,000	175.0	163.0	26.5	6.3	0.61	2,200	2,300	-
	9,000	15,000	170.0	158.0	25.3	6.1	0.60	2,100	2,200	-
	8,000	13,000	164.0	152.0	24.1	5.9	0.59	1,900	2,000	-
	7,000	12,000	161.0	149.0	23.5	5.8	0.58	1,800	1,900	-
	6,500	10,500	155.0	144.0	22.7	5.6	0.56	1,700	1,800	-
	5,000	8,600	133.0	124.0	21.6	5.4	0.58	1,420	1,500	-
	3,000	5,300	110.0	102.0	19.0	4.7	0.57	950	1,000	-
	2,000	3,500	95.0	87.0	17.1	4.1	0.56	760	800	-
1,000	1,800	74.0	68.0	14.6	3.3	0.54	570	600	-	

Note: Dimensions given in tables may vary up to ±10% depending on construction and country of origin (this note comes from the origin document WG121)

# Ship Tables

TYPE	DWT (t)	DISPLACEMENT (t)	L <sub>OA</sub> (m)	L <sub>pp</sub> (m)	B (m)	LADEN DRAFT (m)	C <sub>B</sub> (-)	MIN. LATERAL WINDAGE: FULLY LOADED (m <sup>2</sup> )	MAX. LATERAL WINDAGE: IN BALLAST (m <sup>2</sup> )	APPROX. CAPACITY: TEU / CEU
Fast Ferries (multihull)	9,000	3,200	127.0	117.0	30.5	4.3	0.43	1,850	2,000	–
	6,000	2,100	107.0	93.0	26.5	3.7	0.43	1,550	1,650	–
	5,000	1,700	97.0	83.0	24.7	3.4	0.43	1,250	1,250	–
	4,000	1,400	92.0	79.0	24.0	3.2	0.42	1,120	1,200	–
	2,000	700	85.0	77.0	21.2	3.1	0.39	1,070	1,150	–
	1,000	350	65.0	62.0	16.7	2.1	0.37	820	900	–
	500	175	46.0	41.0	13.8	1.8	0.35	460	500	–
250	95	42.0	37.0	11.6	1.6	0.35	420	450	–	

TYPE	DWT (t)	DISPLACEMENT (t)	L <sub>OA</sub> (m)	L <sub>pp</sub> (m)	B (m)	LADEN DRAFT (m)	C <sub>B</sub> (-)	MIN. LATERAL WINDAGE: FULLY LOADED (m <sup>2</sup> )	MAX. LATERAL WINDAGE: IN BALLAST (m <sup>2</sup> )	APPROX. CAPACITY: PASSENGERS
Cruise Liners (Post Panamax)	220,000	115,000	360.0	333.0	55.0	9.2	0.67	15,700	16,000	5,400 / 7,500
	160,000	84,000	339.0	313.6	43.7	9.0	0.66	13,800	14,100	3,700 / 5,000
	135,000	71,000	333.0	308.0	37.9	8.8	0.67	13,100	13,400	3,200 / 4,500
	115,000	61,000	313.4	290.0	36.0	8.6	0.66	11,950	12,200	3,000 / 4,200
	105,000	56,000	294.0	272.0	35.0	8.5	0.67	10,800	11,000	2,700 / 3,500
	95,000	51,000	295.0	273.0	33.0	8.3	0.67	10,400	10,600	2,400 / 3,000
	80,000	44,000	272.0	231.0	35.0	8.0	0.66	8,800	9,000	2,000 / 2,800
Cruise Liners (Panamax)	90,000	48,000	294.0	272.0	32.2	8.0	0.67	10,400	10,600	2,000 / 2,800
	80,000	43,000	280.0	248.7	32.2	7.9	0.66	9,100	9,300	1,800 / 2,500
	70,000	38,000	265.0	225.0	32.2	7.8	0.66	8,500	8,700	1,700 / 2,400
	60,000	34,000	252.0	214.0	32.2	7.6	0.63	7,250	7,400	1,600 / 2,200
	60,000	34,000	251.2	232.4	28.8	7.6	0.65	7,850	8,000	1,600 / 2,200
	50,000	29,000	234.0	199.0	32.2	7.1	0.62	6,450	6,600	1,400 / 1,800
	50,000	29,000	232.0	212.0	28.0	7.4	0.64	6,850	7,000	1,400 / 1,800
	40,000	24,000	212.0	180.0	32.2	6.5	0.62	5,600	5,700	1,200 / 1,600
	40,000	24,000	210.0	192.8	27.1	7.0	0.64	5,900	6,000	1,200 / 1,600
	35,000	21,000	192.0	164.0	32.0	6.3	0.62	4,800	4,900	1,000 / 1,400
	35,000	21,000	205.0	188.0	26.3	6.8	0.61	5,500	5,600	1,000 / 1,400
	30,000	18,200	190.0	175.0	25.0	6.7	0.61	4,600	4,700	850 / 1,200
	25,000	16,200	180.0	165.0	24.0	6.6	0.60	3,920	4,000	700 / 1,000
	20,000	14,000	169.0	155.0	22.5	6.5	0.60	3,430	3,500	600 / 800
	15,000	11,500	152.0	140.0	21.0	6.4	0.60	2,940	3,000	350 / 500
10,000	8,000	134.0	123.0	18.5	5.8	0.59	2,350	2,400	280 / 400	
5,000	5,000	100.0	90.0	16.5	5.6	0.59	1,570	1,600	200 / 300	
Ocean-going Fishing Vessels	7,500	9,100	128.0	120.0	17.1	6.8	0.64	810	840	–
	5,000	6,200	106.0	100.0	16.1	6.2	0.61	650	670	–
	3,000	4,200	90.0	85.0	14.0	5.9	0.58	550	570	–
	2,500	3,500	85.0	81.0	13.0	5.6	0.58	500	520	–
	2,000	2,700	80.0	76.0	12.0	5.3	0.54	470	490	–
	1,500	2,200	76.0	72.0	11.3	5.1	0.52	430	450	–
	1,200	1,900	72.0	68.0	11.0	5.0	0.50	400	420	–
	1,000	1,600	70.0	66.0	10.5	4.8	0.47	380	400	–
	700	1,250	65.0	62.0	10.0	4.5	0.44	345	360	–
	500	800	55.0	53.0	8.6	4.0	0.43	290	300	–
	250	400	40.0	38.0	7.0	3.5	0.42	190	200	–
150	300	32.0	28.0	7.5	3.4	0.41	135	140	–	

Note: Dimensions given in tables may vary up to ±10% depending on construction and country of origin (this note comes from the origin document WG121)

# Ship Tables

TYPE	DWT (t)	DISPLACEMENT (t)	L <sub>OA</sub> (m)	L <sub>PP</sub> (m)	B (m)	LADEN DRAFT (m)	C <sub>B</sub> (-)	MIN. LATERAL WINDAGE: FULLY LOADED (m <sup>2</sup> )	MAX. LATERAL WINDAGE: IN BALLAST (m <sup>2</sup> )	APPROX. CAPACITY: (m <sup>3</sup> )
<b>Coastal Fishing Vessels</b>	100	200	27.0	23.0	7.0	3.1	0.39	-	-	-
	75	165	25.0	22.0	6.6	2.8	0.40	-	-	-
	50	115	21.0	17.0	6.2	2.7	0.39	-	-	-
	25	65	15.0	12.0	5.5	2.6	0.37	-	-	-
	15	40	11.0	9.2	5.0	2.3	0.37	-	-	-
<b>Motor Yachts</b>	-	9,500	160.0	135.0	21.8	5.5	-	-	-	-
	-	7,000	140.0	120.0	23.5	5.0	-	-	-	-
	-	4,500	120.0	102.0	18.5	4.9	-	-	-	-
	-	3,500	100.0	85.0	16.5	4.8	-	-	-	-
	-	1,600	70.0	60.0	13.5	3.8	-	-	-	-
	-	1,100	60.0	51.0	12.0	3.6	-	-	-	-
	-	700	50.0	43.0	9.0	3.5	-	-	-	-
	-	500	45.0	39.0	8.5	3.3	-	-	-	-
	-	250	40.0	24.0	8.0	3.0	-	-	-	-
	-	150	30.0	25.0	7.5	2.9	-	-	-	-
<b>Motor Boats</b>	-	35.0	21.0	-	5.0	3.0	-	-	-	-
	-	27.0	18.0	-	4.4	2.7	-	-	-	-
	-	16.5	15.0	-	4.0	2.3	-	-	-	-
	-	6.5	12.0	-	3.4	1.8	-	-	-	-
	-	4.5	9.0	-	2.7	1.5	-	-	-	-
	-	1.3	6.0	-	2.1	1.0	-	-	-	-
<b>Sailing Yachts</b>	-	1,500	90.0	67.5	13.5	6.5	-	-	-	-
	-	1,000	70.0	51.5	11.5	6.0	-	-	-	-
	-	650	60.0	42.0	11.2	5.5	-	-	-	-
	-	550	50.0	37.5	9.5	5.0	-	-	-	-
	-	190	40.0	35.0	9.3	4.5	-	-	-	-
	-	125	30.0	28.0	7.2	3.6	-	-	-	-
	-	40	20.0	17.5	5.5	3.0	-	-	-	-
	-	13	15.0	11.2	4.5	2.5	-	-	-	-
<b>Sailing Boats</b>	-	10	12.0	11.0	3.8	2.3	-	-	-	-
	-	5	10.0	9.5	3.5	2.1	-	-	-	-
	-	1.5	6.0	5.7	2.4	1.5	-	-	-	-
	-	1.0	5.0	4.3	2.0	1.0	-	-	-	-
	-	0.8	2.5	2.3	1.5	0.5	-	-	-	-

Note: Dimensions given in tables may vary up to ±10% depending on construction and country of origin (this note comes from the origin document WG121)

# Structures

The preferred jetty structure can influence the fender design and vice versa. The type of structure depends on local practice, the geology at the site, available materials and other factors.

Selecting an appropriate fender at an early stage can have a major effect on the overall project cost. Below are some typical structures and fender design considerations.

	FEATURES	DESIGN CONSIDERATIONS
<b>Open pile jetties</b> 	<ul style="list-style-type: none"> <li>■ Simple and cost-effective</li> <li>■ Good for deeper waters</li> <li>■ Load-sensitive</li> <li>■ Limited fixing area for fenders</li> <li>■ Vulnerable to bulbous bows</li> </ul>	<ul style="list-style-type: none"> <li>■ Low reaction reduces pile sizes and concrete mass</li> <li>■ Best to keep fixings above piles and low tide</li> <li>■ Suits cantilever panel designs</li> </ul>
<b>Dolphins</b> 	<ul style="list-style-type: none"> <li>■ Common for oil and gas terminals</li> <li>■ Very load-sensitive</li> <li>■ Flexible structures need careful design to match fender loads</li> <li>■ Structural repairs are costly</li> </ul>	<ul style="list-style-type: none"> <li>■ Few but large fenders</li> <li>■ Total reliability needed</li> <li>■ Low reactions preferred</li> <li>■ Large panels for low hull pressures need chains etc</li> </ul>
<b>Monopiles</b> 	<ul style="list-style-type: none"> <li>■ Inexpensive structures</li> <li>■ Loads are critical</li> <li>■ Not suitable for all geologies</li> <li>■ Suits remote locations</li> <li>■ Quick to construct</li> </ul>	<ul style="list-style-type: none"> <li>■ Fenders should be designed for fast installation</li> <li>■ Restricted access means low maintenance fenders</li> <li>■ Low reactions must be matched to structure</li> <li>■ Parallel motion systems</li> </ul>
<b>Mass structures</b> 	<ul style="list-style-type: none"> <li>■ Most common in areas with small tides</li> <li>■ Fender reaction not critical</li> <li>■ Avoid fixings spanning pre-cast and in situ sections or expansion joints</li> </ul>	<ul style="list-style-type: none"> <li>■ Keep anchors above low tide</li> <li>■ Care needed selecting fender spacing and projection</li> <li>■ Suits cast-in or retrofit anchors</li> <li>■ Many options for fender types</li> </ul>
<b>Sheet piles</b> 	<ul style="list-style-type: none"> <li>■ Quick to construct</li> <li>■ Mostly used in low corrosion regions</li> <li>■ In situ concrete copes are common</li> <li>■ Can suffer from ALWC (accelerated low water corrosion)</li> </ul>	<ul style="list-style-type: none"> <li>■ Fixing fenders direct to piles difficult due to build tolerances</li> <li>■ Keep anchors above low tide</li> <li>■ Care needed selecting fender spacing and projection</li> </ul>

# Approach

## Side berthing

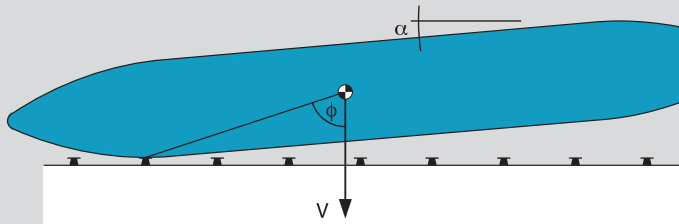

Typical values

$$0^\circ \leq \alpha \leq 15^\circ$$

$$100 \text{ mm/s} \leq V \leq 300 \text{ mm/s}$$

$$60^\circ \leq \phi \leq 90^\circ$$

## Dolphin berthing

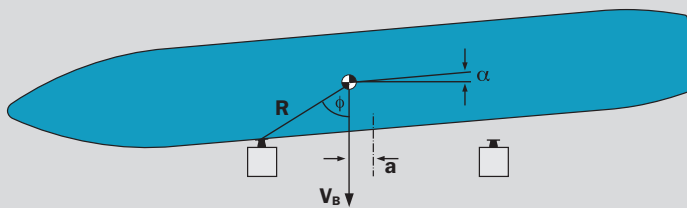

Typical values

$$0^\circ \leq \alpha \leq 10^\circ$$

$$100 \text{ mm/s} \leq V \leq 200 \text{ mm/s}$$

$$30^\circ \leq \phi \leq 90^\circ$$

## End berthing

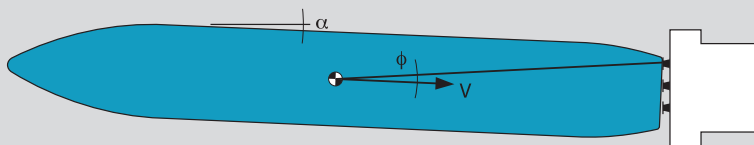

Typical values

$$0^\circ \leq \alpha \leq 15^\circ$$

$$150 \text{ mm/s} \leq V \leq 500 \text{ mm/s}$$

$$0^\circ \leq \phi \leq 15^\circ$$

## Lock entrances

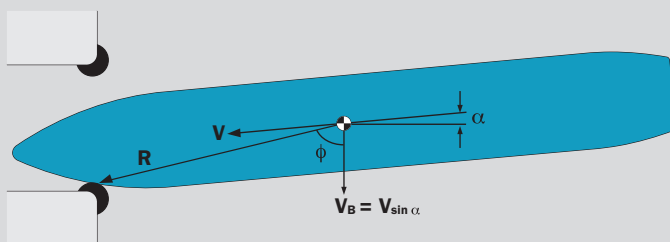

Typical values

$$0^\circ \leq \alpha \leq 30^\circ$$

$$300 \text{ mm/s} \leq V \leq 2000 \text{ mm/s}$$

$$0^\circ \leq \phi \leq 30^\circ$$

## Ship-to-ship berthing

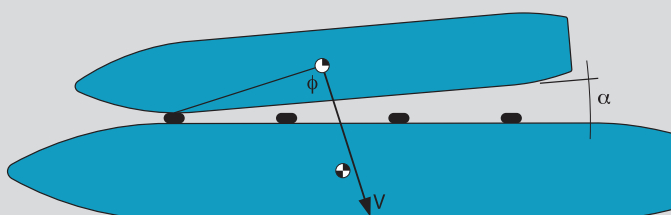

Typical values

$$0^\circ \leq \alpha \leq 15^\circ$$

$$150 \text{ mm/s} \leq V \leq 500 \text{ mm/s}$$

$$60^\circ \leq \phi \leq 90^\circ$$

# Approach Velocity ( $V_B$ )

Berthing speeds depend on the ease or difficulty of the approach, the exposure of the berth and the vessel's size. Conditions are normally divided into five categories as shown in the chart's key table.

The most widely used guide to approach speeds is the Brolsma table, adopted by BS, PIANC and other standards.

For ease of use, speeds for the main vessel sizes are shown below.

**Berthing Speeds indicated in the Table is based on PIANC Guidelines for the Design of Fender Systems, 2002**

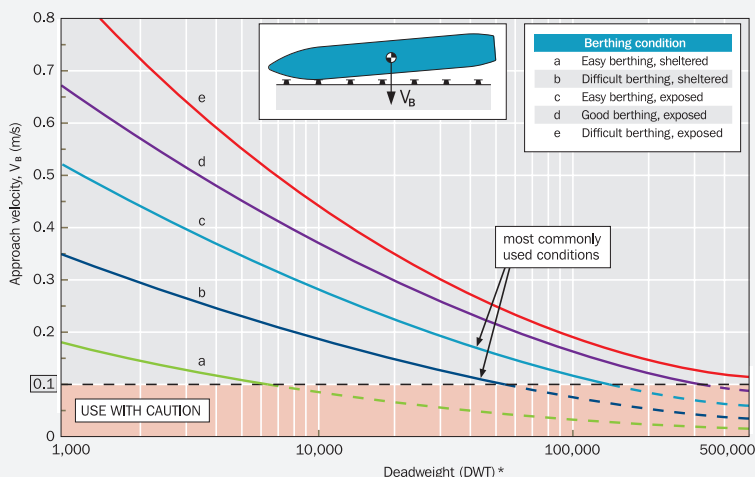

\*PIANC suggests using DWT from 50% or 75% confidence limit ship tables.

**BS 6349-4:2014**

Design berthing velocity as function of navigation conditions and size of vessel

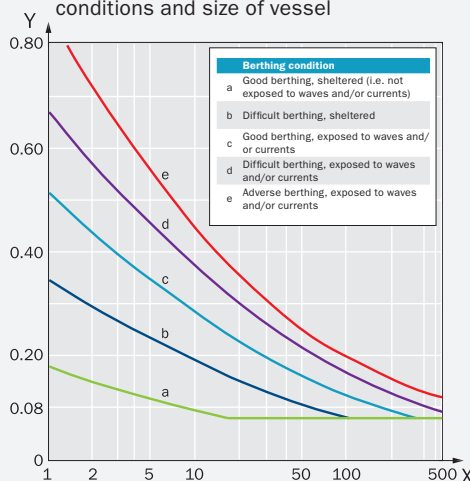

**Key –** X Water displacement, in 1000 t  
Y Characteristic velocity, in m/s, perpendicular to the berth

DWT	VELOCITY, $V_B$ (m/s)				
	a	b	c	d	e
1,000	0.179	0.343	0.517	0.669	0.865
2,000	0.151	0.296	0.445	0.577	0.726
3,000	0.136	0.269	0.404	0.524	0.649
4,000	0.125	0.250	0.374	0.487	0.597
5,000	0.117	0.236	0.352	0.459	0.558
10,000	0.094	0.192	0.287	0.377	0.448
20,000	0.074	0.153	0.228	0.303	0.355
30,000	0.064	0.133	0.198	0.264	0.308
40,000	0.057	0.119	0.178	0.239	0.279
50,000	0.052	0.110	0.164	0.221	0.258
100,000	0.039	0.083	0.126	0.171	0.201
200,000	0.028	0.062	0.095	0.131	0.158
300,000	0.022	0.052	0.080	0.111	0.137
400,000	0.019	0.045	0.071	0.099	0.124
500,000	0.017	0.041	0.064	0.090	0.115

- Approach velocities less than 0.1 m/s should be used with caution
- Values are for tug-assisted berthing.
- Spreadsheets for calculating the approach velocity and berthing energy are available.

- Actual berthing velocities can be measured, displayed and recorded using a SmartDock Docking Aid System (DAS) by Trelleborg Marine and Infrastructure.



## Block Coefficient ( $C_B$ )

The Block Coefficient ( $C_B$ ) is a function of the hull shape and is expressed as follows:

$$C_B = \frac{M_D}{L_{BP} \times B \times D \times \rho_{SW}}$$

where,

- $M_D$  = displacement of vessel (t)
- $L_{BP}$  = length between perpendiculars (m)
- $B$  = beam of vessel (m)
- $D$  = draft of vessel (m)
- $\rho_{SW}$  = seawater density  $\approx 1.025 \text{ t/m}^3$

Given ship dimensions and using typical block coefficients, the displacement can be estimated:

$$M_D \approx C_B \times L_{BP} \times B \times D \times \rho_{SW}$$

Typical block coefficients ( $C_B$ )

Container vessels	0.6–0.8
General cargo and bulk carriers	0.72–0.85
Tankers	0.85
Ferries	0.55–0.65
RoRo vessels	0.7–0.8

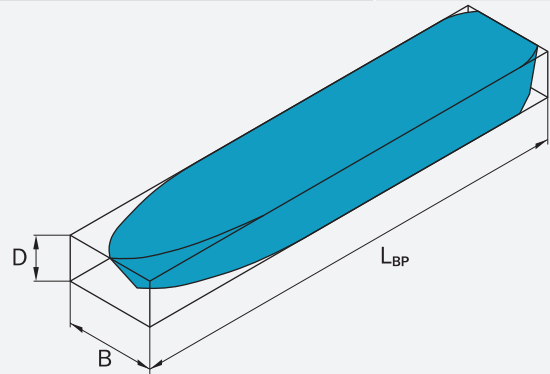

## Added Mass Coefficient ( $C_M$ )

The Added Mass Coefficient ( $C_M$ ) allows for the body of water carried along with the ship as it moves sideways through the water. As the ship is stopped by the fender, the entrained water continues to push against the ship, effectively increasing its overall mass. The Vasco Costa method is adopted by most design codes for ship-to-shore berthing where water depths are not substantially greater than vessel drafts.

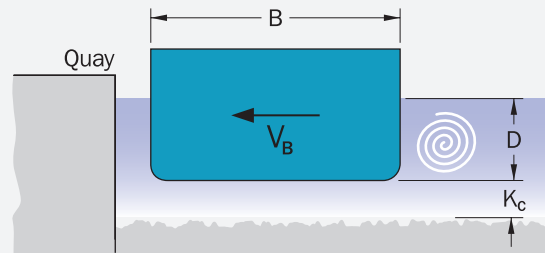

PIANC (2002)	SHIGERA UEDA (1981)	VASCO COSTA* (1964)
for $\frac{K_C}{D} \leq 0.1$ $C_M = 1.8$		
for $0.1 \leq \frac{K_C}{D} \leq 0.5$ $C_M = 1.875 - 0.75 \left[ \frac{K_C}{D} \right]$		
for $\frac{K_C}{D} \geq 0.5$ $C_M = 1.5$		

where,

- $D$  = draft of vessel (m)
- $B$  = beam of vessel (m)
- $L_{BP}$  = length between perpendiculars (m)
- $K_C$  = under keel clearance (m)

\*valid where  $V_B \geq 0.08 \text{ m/s}$ ,  $K_C \geq 0.1D$

### Special case – longitudinal approach

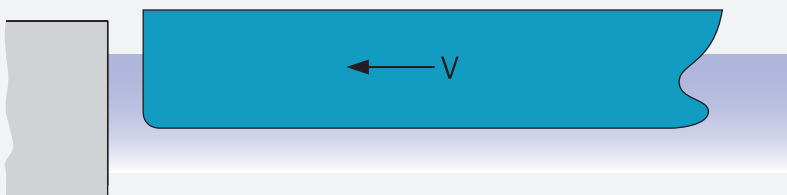

$C_M = 1.1$   
Recommended by PIANC

## Eccentricity Coefficient ( $C_E$ )

The Eccentricity Coefficient ( $C_E$ ) allows for the energy dissipated by rotation of the ship about its point of impact with the fenders. The correct point of impact, berthing angle and velocity vector angle are all

$V_L$  = longitudinal velocity component (forward or astern)

$$x + y = \frac{L_{BP}}{2} \quad (\text{assuming the center of mass is at mid-length of the ship})$$

$$R = \sqrt{y^2 + \left[\frac{B}{2}\right]^2}$$

$$K = (0.19 \times C_B + 0.11) \times L_{BP}$$

$$C_E = \frac{K^2 + R^2 \cos^2 \phi}{K^2 + R^2}$$

where,

$B$  = beam of vessel (m)

$C_B$  = block coefficient

$L_{BP}$  = length between perpendiculars (m)

$R$  = center of mass to point of impact (m)

$K$  = radius of gyration (m)

**Caution:** for  $\phi < 10^\circ$ ,  $C_E \rightarrow 1.0$

important for accurate calculation of the eccentricity coefficient. In practice,  $C_E$  often varies between 0.3 and 1.0 for different berthing cases. Velocity ( $V$ ) is not always perpendicular to the berthing line.

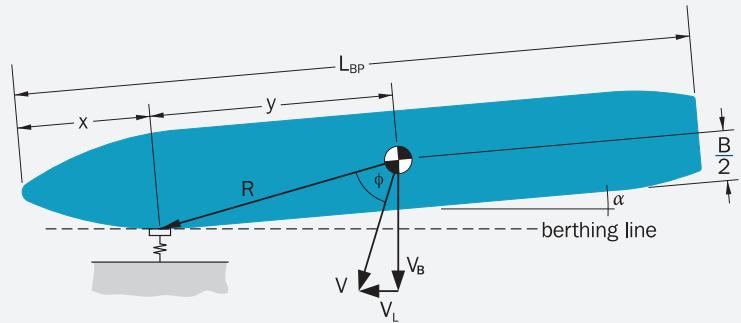

### COMMON BERTHING CASES

#### Quarter-point berthing

$$x = \frac{L_{BP}}{4} \quad C_E \approx 0.4-0.6$$

#### Third-point berthing

$$x = \frac{L_{BP}}{3} \quad C_E \approx 0.6-0.8$$

#### Midships berthing

$$x = \frac{L_{BP}}{2} \quad C_E \approx 1.0$$

## LOCK ENTRANCES AND GUIDING FENDERS

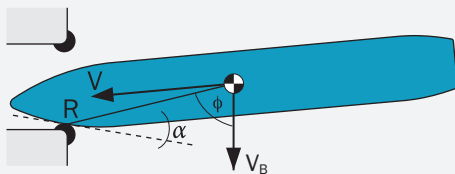

In cases where the ship has a significant forward motion, it is suggested by PIANC that the ship's speed parallel to the berthing face ( $V \cos \alpha$ ) is not decreased by berthing impacts and it is the transverse velocity component  $V_B$  ( $V \sin \alpha$ ) which must be resisted by the fenders. When calculating the Eccentricity Coefficient, the velocity vector angle ( $\phi$ ) is taken between  $V_B$  and  $R$ .

## DOLPHIN BERTHS

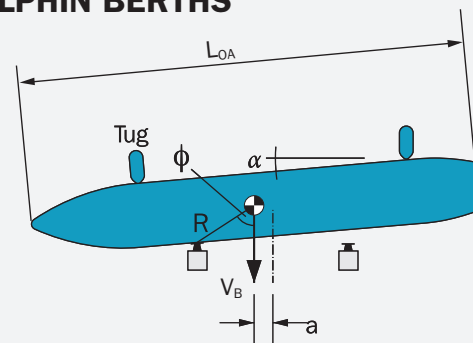

Ships will rarely berth exactly centrally against the berthing dolphins. The dolphin pairs are usually placed at 0.25 – 0.4 times the overall length ( $L_{OA}$ ) of the design vessel. When calculating  $R$  and  $\phi$ , a dimension ( $a$ ) of  $0.1 L_{OA}$ , but not greater than 15 m, from the center of the platform (un)loading system may be assumed. Larger offsets will increase the Eccentricity Coefficient. In extreme cases where  $V_B$  is coaxial with the fender,  $C_E = 1$ .

# Eccentricity Coefficient ( $C_E$ )

## SPECIAL CASES FOR FERRY AND RO-RO BERTHS

Ferry and Ro-Ro vessels commonly use two different berthing modes. BS6349-4:2014 defines these as mode (a) and mode (b).

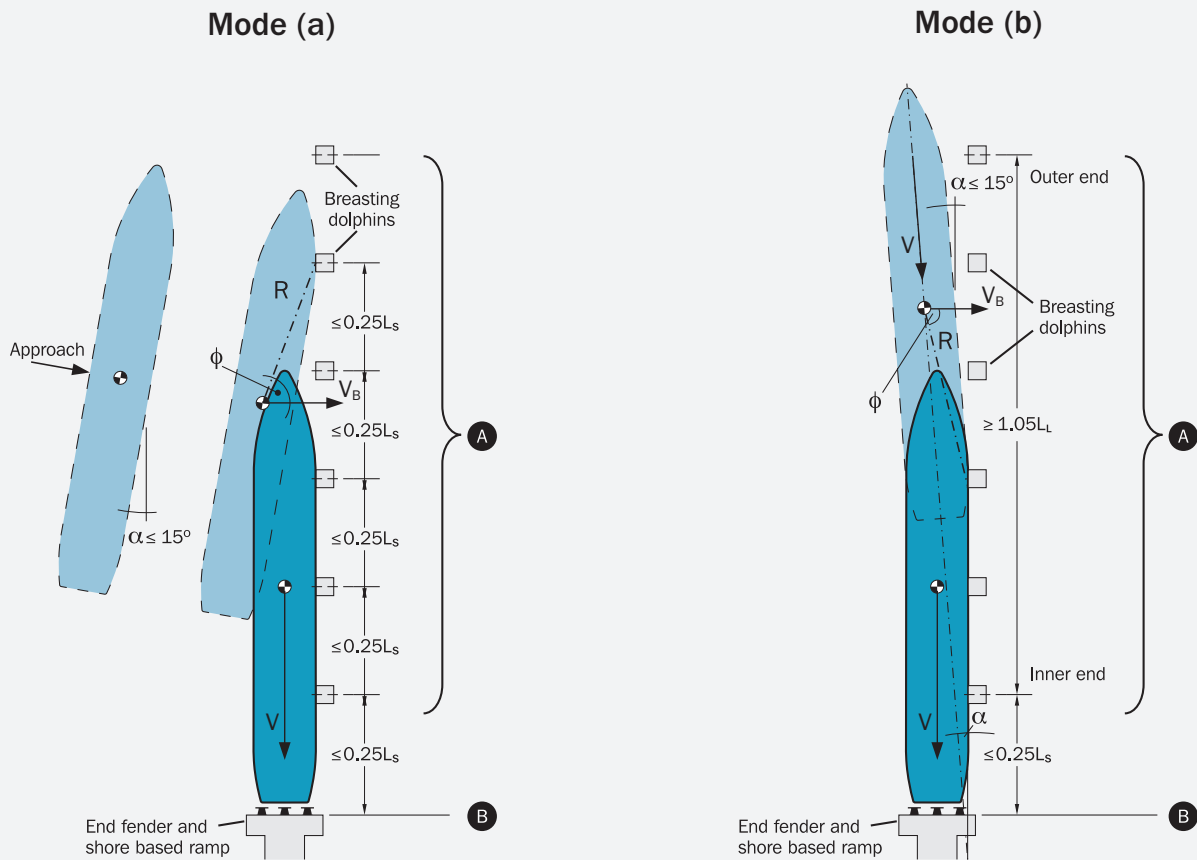

MODE (a)			
	Fender	Characteristic Velocity of Vessel	Angle of Approach of Vessel ( $\alpha$ )
A	Side	$V_B =$ as per the Brolsma table	$0^\circ \sim \leq 15^\circ$
B	End	$V = 0.15$ m/s	$0^\circ$

MODE (b)			
	Fender	Characteristic Velocity of Vessel	Angle of Approach of Vessel ( $\alpha$ )
A	Side	$V = 0.5$ m/s to $1.0$ m/s *	$\geq 10^\circ$
B	End	$V = 0.3$ m/s to $0.5$ m/s	$\leq 15^\circ$

Ferry and Ro-Ro vessels make a parallel approach to a row of breasting dolphins or quay and after coming to rest then moving slowly longitudinally to berth end on or against a shore ramp structure.

Ferry and Ro-Ro vessels make a direct longitudinal approach to berth end-on against or close to a shore ramp structure but using side breasting dolphins or a quay as a guide.

$$C_M = 1.1 \text{ for Side Fenders}$$

$$* V_B = V \sin$$

## Berth Configuration Coefficient ( $C_c$ )

When ships berth at small angles against solid structures, the water between hull and quay acts as a cushion and dissipates a small part of the berthing energy. The extent to which this factor contributes will depend upon several factors:

- Quay structure design
- Under keel clearance
- Velocity and angle of approach
- Projection of fender
- Vessel hull shape

PIANC recommends the following values:

$C_c = 1.0$	<ul style="list-style-type: none"> <li>■ Open structures including berth corners</li> <li>■ Berthing angles <math>&gt; 5^\circ</math></li> <li>■ Very low berthing velocities</li> <li>■ Large under keel clearance</li> </ul>
$C_c = 0.9$	<ul style="list-style-type: none"> <li>■ Solid quay walls under parallel approach (berthing angles <math>&lt; 5^\circ</math>) and under keel clearance less than 15% of the vessel draught</li> </ul>

Note: where the under keel clearance has already been considered for added mass ( $C_m$ ), the berth configuration coefficient  $C_c=1$  is usually assumed.

### Closed structure

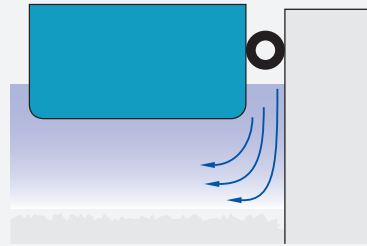

### Semi-closed structure

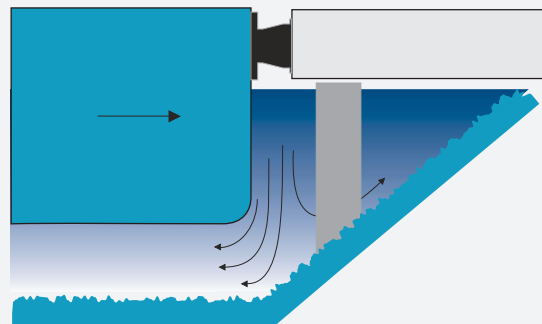

### Open structure

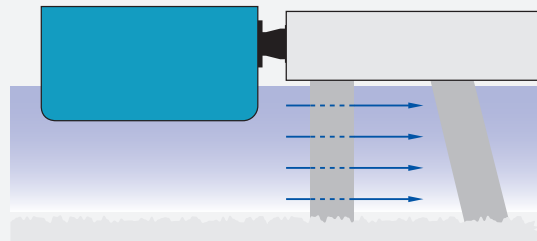

## Softness Coefficient ( $C_s$ )

Where fenders are hard relative to the flexibility of the ship hull, some of the berthing energy is absorbed by elastic deformation of the hull. In most cases this contribution is limited and ignored ( $C_s=1$ ). PIANC recommends the following values:

$C_s = 1.0$	Soft fenders ( $\delta_f > 150\text{mm}$ )
$C_s = 0.9$	Hard fenders ( $\delta_f \leq 150\text{mm}$ )



# Berthing Energy Calculation

The kinetic energy of a berthing ship needs to be absorbed by a suitable fender system and this is most

commonly carried out using well recognized deterministic methods as outlined in the following sections.

## NORMAL BERTHING ENERGY (E<sub>N</sub>)

Most berthings will have energy less than or equal to the normal berthing energy (E<sub>N</sub>). The calculation should take into account worst combinations of vessel displacement, velocity, angle as well as the various coefficients.

Allowance should also be made for how often the berth is used, any tidal restrictions, experience of the operators, berth type, wind and current exposure.

The normal energy to be absorbed by the fender can be calculated as:

$$E_N = 0.5 \times M_D \times V_B^2 \times C_M \times C_E \times C_C \times C_S$$

Where,

- E<sub>N</sub> = Normal berthing energy to be absorbed by the fender (kJNm)
- M<sub>D</sub> = Mass of the vessel (displacement in tonne) at chosen confidence level\*
- V<sub>B</sub> = Approach velocity component perpendicular to the berthing line (m/s)<sup>†</sup>
- C<sub>M</sub> = Added mass coefficient
- C<sub>E</sub> = Eccentricity coefficient
- C<sub>C</sub> = Berth configuration coefficient
- C<sub>S</sub> = Softness coefficient

\* PIANC suggests 50% or 75% confidence limits (M<sub>50</sub> or M<sub>75</sub>) are appropriate to most cases.

† Berthing velocity (V<sub>B</sub>) is usually based on displacement at 50% confidence limit (M<sub>50</sub>).

## ABNORMAL BERTHING ENERGY (E<sub>A</sub>)

Abnormal impacts arise when the normal energy is exceeded. Causes may include human error, malfunctions, exceptional weather conditions or a combination of these factors.

The abnormal energy to be absorbed by the fender can be calculated as:

$$E_A = F_S \times E_N$$

Where,

E<sub>A</sub> = Abnormal berthing energy to be absorbed by the fender (kJNm)

F<sub>S</sub> = Safety factor for abnormal berthings.

Choosing a suitable safety factor (F<sub>S</sub>) will depend on many factors:

- The consequences a fender failure may have on berth operations
- How frequently the berth is used
- Very low design berthing speeds which might easily be exceeded
- Vulnerability to damage of the supporting structure
- Range of vessel sizes and types using the berth
- Hazardous or valuable cargoes including people

### PIANC Factors of Safety (F<sub>S</sub>)

VESSEL TYPE	SIZE	F <sub>S</sub>
Tanker, bulk, cargo	Largest	1.25
	Smallest	1.75
Container	Largest	1.5
	Smallest	2.0
General cargo	–	1.75
RoRo, ferries	–	≥ 2.0
Tugs, workboats, etc	–	2.0

Source: PIANC 2002; Table 4.2.5.

PIANC recommends that 'the factor of abnormal impact when derived should not be less than 1.1 nor more than 2.0 unless exception circumstances prevail'. Source: PIANC 2002; Section 4.2.8.5.

# Fender Selection & Fender Systems Design



POLAND

Designing an efficient fender system involves selecting the right materials.

This will result in a safe, low maintenance and long lasting fender system, increasing port efficiency and providing longer life cycle cost.

## Fender Selection

Every type and size of fender has different performance characteristics (please refer to Fender Systems brochure). Whatever type of fenders are used, they must have sufficient capacity to absorb the normal and abnormal energies of berthing ships.

When selecting fenders the designer must consider many factors including:

- Single or multiple fender contacts
- The effects of angular compressions
- Approach speeds
- Extremes of temperature
- Berthing frequency
- Fender efficiency

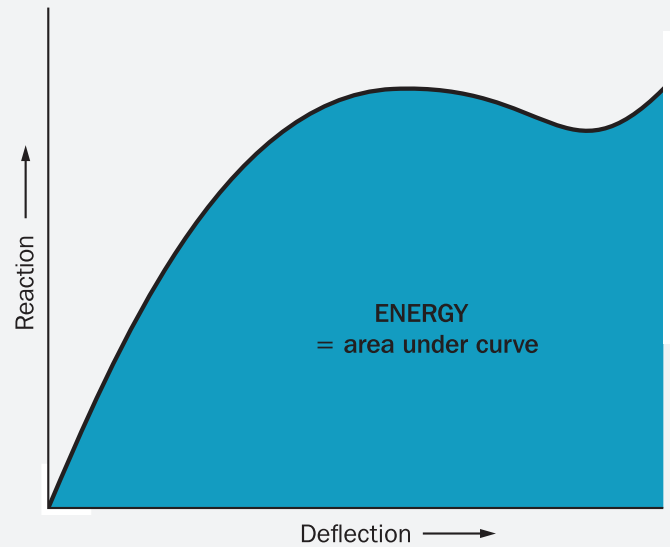

## GUIDELINES TO FENDER SELECTION

There are two fundamental criteria for selection of fenders.

1. The energy capacity of the fender under the worst operating conditions must be greater than the abnormal design Berthing Energy  $E_A$ .
2. The reaction force created by the fender onto the structure/vessel must be less than the capacity/hull pressure limit of the structure/vessel. The local condition, for e.g. temperature range, angle, impact velocity and manufacturing tolerance, needs to be accounted for to determine the operating capacity of the fender.

This is summarized by the following formula:

$$E_A \leq E_{cv} \times TOL \times VF \times TF \times AF$$

– Temperature (maximum)

– Velocity (minimum)

$E_A$  = Abnormal berthing energy

$E_{cv}$  = Constant velocity performance

TOL = Manufacturing tolerance (typ -10%)

TF = Temperature factor\*

VF = Velocity factor\*

AF = Angle factor\*

$$R \geq R_{cv} \times TOL \times VF \times TF \times AF$$

– Temperature (minimum)

– Velocity (maximum)

R = Reaction force

$R_{cv}$  = Constant velocity performance

TOL = Manufacturing tolerance (typ +10%)

TF = Temperature factor\*

VF = Velocity factor\*

AF = Angle factor\*

\* Refer to TF/VF/AF table on pages 31-41

## Correction factors

An understanding of rubber compound composition is key in designing a robust fender system.

Through extensive testing, Trelleborg has established that rubber composition has a great influence on velocity factor (VF), temperature factor (TF), efficiency and longevity of rubber fenders.

### VELOCITY FACTOR (VF)

#### Rheology: non-linear engineering

The behavior of rubber under stress is unique. It is recognized in the theory of “Rheology”, which describes the flow of polymers under stress. Through rheology, we understand that the stress or reaction force produced by a rubber fender during compression not only depends on strain level, but also on strain rate (how quickly the strain is induced).

- This means that when a rubber fender is compressed, the resultant reaction force and energy absorption are greater when the compression occurs at higher speeds.
- Currently, performance data from most manufacturers is presented with a berthing velocity of 2 - 8 cm/min, and rarely is there advice on the effects of high impact velocity. The difference between this and actual real life conditions (those used for the design of fender systems and wharf structures) needs to be accounted for in the engineering design.

#### Definition

- Typically, normal berthing velocity of vessels is from 20 mm/sec to 500 mm/sec. In a perfect world, fender manufacturers would test at actual berthing velocities to determine the performance of the fenders. However, in practice this is exceptionally difficult given the size of investment in equipment and range of fenders to be tested.
- PIANC’s 2002 “Guidelines for the Design of Fender Systems” highlighted the importance of VF in design and selection of fenders, and introduced guidelines for calculating and reporting VF.

VF is defined as below:

$$VF = \frac{\text{Reaction force at impact speed}}{\text{Reaction force at testing speed}}$$

For a given velocity, there are two factors that have the greatest influence on VF. Strain Rate (inverse of compression time) and the type of rubber used in the fender.

#### Strain Rate

- Reaction force of a fender is directly proportional to the strain rate.
- For a given velocity, a large fender needs more time to be compressed than a smaller one. At the same berthing velocity, the strain rate on a large fender will be lower than on a small fender and hence, magnitude of VF will be lower.

#### Type of Rubber used

- The second factor that greatly influences VF is the type of raw rubber used in compound formulation. Test results showed that given the same compression time, a fender comprised of 100% natural rubber (NR) will have a lower velocity factor (VF) than a fender comprised of 100% synthetic based rubber (SBR).
- This is due to differing rates of Stress Relaxation between NR and SBR and relates to differences in the microstructure in the respective polymer chains.

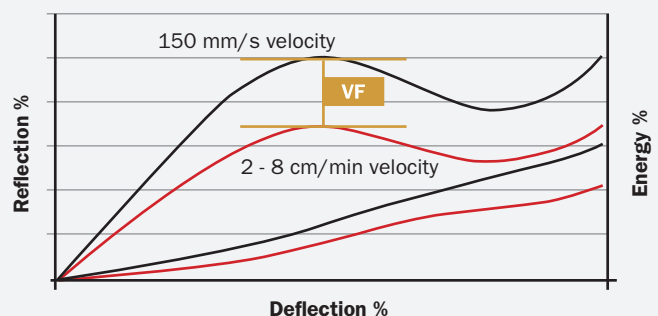

VF: ratio of reaction force at berthing speed and testing speed





KEY WEST, UNITED STATES

## Correction factors

### FACTORS IMPACTING THE MAGNITUDE OF VF

- Compression speed or strain rate
- Chemical composition of rubber compounds

FENDER	SCN 300	SCN 300	SCN 2000
Height	300 mm	300 mm	2000 mm
Compression speed	1 mm/s	150 mm/s	150 mm/s
Compression time (rated deflection / compression speed x deceleration factor)	291 sec	1.95 sec	12.97 sec
Strain rate (compression speed / rated deflection)	$1/216 = 0.005/s$	$150/216 = 0.694/s$	$150/1440 = 0.104/s$
VF (NR+SBR)	1.00	1.16	1.06
VF (100% NR)	1.00	1.10	1.02

The higher the strain rate, the higher is the VF.

### THE IMPACT OF VF

- The magnitude of VF in most cases will have an impact on fender performance characteristics (Reaction Force and Energy Absorption) at normal design berthing speeds, and by default the design of fender system components (frontal frames, chains and anchors) as well as wharf structure.
- Using VF, performance figures should be adjusted to account for design berthing velocity. In general we would expect increased reaction force, and a corresponding increase in energy absorption.
- The fender system design will need to account for the increased reaction force in relation to restraint chain and fixing anchor design, as well as forces applied to the frontal frames. In addition, the increased reaction force loads will need to be reviewed against the structural design of the wharf (quay wall, or dolphin etc.).
- It's essential that manufacturers incorporate guidance on the effects of VF on their fenders. When comparing catalogue figures from different manufacturers, it's essential to ensure VF is applied or performance has been reported at the same test speed to make sure fenders are compared on the same ground.

### TEMPERATURE FACTOR (TF)

- Any factors that have an effect on the stiffness of the rubber compound needs to be taken into consideration during engineering calculation of the berthing energy and reaction force. Failing to do so will have tremendous adverse effect on the berthing structure.
- Temperature Factor refers to the effect of temperature on fender performance. Rubber fenders exhibit different performance characteristics depending on the temperature of the rubber. The magnitude of TF is affected by the type of base polymer used (SBR, NR or a blend of the two).
- Typically, engineering design will review possible minimum and maximum temperature conditions likely to be experienced by a fender. At high temperatures, the fender is effectively softer and as a result, will have a lower energy absorption capacity, whilst at low temperatures the fender is harder and will by default have higher reaction forces which must be accounted for in the design of fender components as well as wharf structure.

## Polymer types

### IMPACT OF POLYMER BLEND ON VF & TF

- The type of polymers used in manufacturing fenders has a substantial impact on VF/TF that must be applied during fender selection.
- Historically most Asian based fender manufacturers have used Natural (NR) based rubber compounds; whilst those in Europe used Synthetic rubber (SBR) based compounds. There was a significant difference of opinion between East and West on Velocity Factor, this being attributable to both the underlying philosophy (strain rate vs. speed) as well as base polymer being used. Unfortunately limited research has been undertaken to explore this further over the last few years.
- Recent research from Trelleborg has highlighted the significant impact that base polymer material has on both VF and TF. Indeed much of the historical argument between fender manufacturers now appears to be attributable to the different base polymer compounds.
- Trelleborg's historical VF and TF have related primarily to NR based compounds (except MV fenders), and current R&D is focused on updating our factors to relate to 100% natural rubber, 100% synthetic rubber and blends of NR/SBR used across our fender range.
- New research indicated that polymer blend ratio can be customized to optimize the application of VF/TF factors to match operational parameters.

### SELECTION OF RUBBER TYPE\*:

- NR/SBR blend:
  - Useful in achieving stable compound properties and fender performance over the years
  - Less damage from ozone/oxygen/heat/UV
  - Better aging properties
- 100% NR compound
  - Preferred if the fenders are used at very low temperatures
  - Fenders are used in load sensitive structures
  - The fenders usage temperature varies extensively from subzero to +30°C
- 100% SBR compound
  - Preferred for berthing at high speed and impact of reaction force is not critical
  - High temperature applications

\*Suggested for typical applications. For critical applications, please contact Trelleborg Marine and Infrastructure offices.

## Correction Factors

### Velocity Factor (VF) Table

COMPRESSION TIME (Seconds)	BLEND OF NATURAL AND SYNTHETIC RUBBER (CATALOGUE COMPOUND)	100% NATURAL RUBBER	100% SYNTHETIC RUBBER (SBR)
	VF	VF	VF
1	1.20	1.14	1.31
2	1.16	1.10	1.25
3	1.14	1.09	1.22
4	1.13	1.07	1.20
5	1.11	1.06	1.19
6	1.10	1.06	1.17
7	1.09	1.05	1.16
8	1.09	1.04	1.15
9	1.08	1.04	1.14
10	1.07	1.03	1.14
11	1.07	1.03	1.13
12	1.06	1.02	1.12
13	1.06	1.02	1.12
14	1.05	1.02	1.11
15	1.05	1.01	1.11
16	1.05	1.01	1.10
17	1.04	1.01	1.10
18	1.04	1.01	1.09
19	1.04	1.00	1.09
20	1.03	1.00	1.08

Compression time (inverse of strain rate) needs to be calculated using the following formula:  $t = d/(f \cdot V_d)$

Where:

$t$  = compression time (seconds)

$d$  = rated deflection (mm)

$V_d$  = initial berthing velocity (mm/s)

$f$  = 0.74 deceleration factor (Peak reaction force occurs at between 30% - 40% deflection, where there has been a deceleration due to energy absorption.  $f$  represents the factor associated with deceleration.)

### Temperature Factor (TF) Table

TEMPERATURE (°C)	BLEND OF NATURAL AND SYNTHETIC RUBBER (CATALOGUE COMPOUND)	100% NATURAL RUBBER	100% SYNTHETIC RUBBER (SBR)
	TF	TF	TF
+50	0.916	0.914	0.918
+40	0.947	0.946	0.948
+30	0.978	0.978	0.979
+23	1.000	1.000	1.000
+10	1.030	1.025	1.038
+0	1.075	1.053	1.108
-10	1.130	1.080	1.206
-20	1.249	1.142	1.410
-30	1.540	1.315	1.877

## Angle Factor (AF) Table

ANGLE (°)	ENERGY FACTOR (SUPER CONE FENDER)	ENERGY FACTOR (SCK CELL FENDER)	REACTION FACTOR
0	1.000	1.000	1.000
3	1.039	0.977	1.000
5	1.055	0.951	1.000
8	1.029	0.909	1.000
10	1.000	0.883	1.000
15	0.856	0.810	0.950
20	0.739	0.652	0.800

The table can be used to estimate fender performance under angular compression (due to bow flare, berthing angle, etc).

## SUPER CONE FENDER

The graph shows fender performance with no chain restraints up to 12 degrees and chain restraints for angles above 12 degrees. Fender is fitted with a standard frontal frame.

**Energy & Reaction Angle Correction Factors**

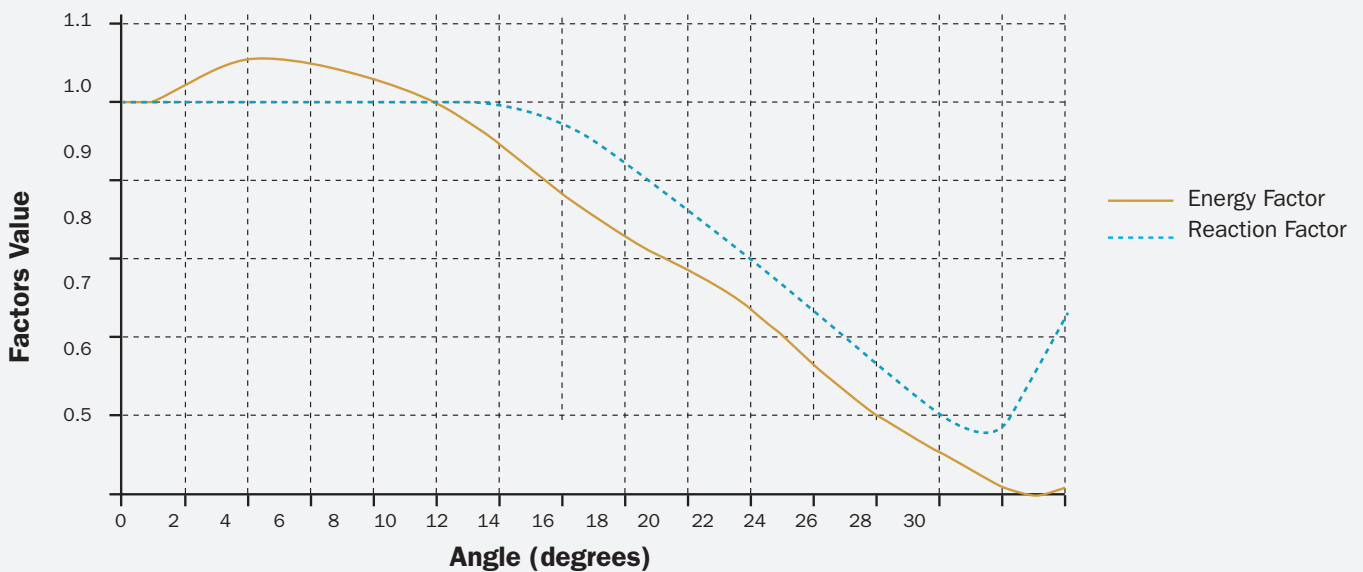

# MV Elements

## ANGLE FACTORS (AF)

### TRANVERSE LOAD

Reduction factor  $R_s$  for energy absorption  $E$  is dependent on the relation between the spacing  $A$  and the dimension  $H$  of the fender element.

Example

2 fender elements MV 1000 x 2000 A

Rated energy absorption  $E = 2 \times 50 = 100$  Tonne-m

Angular berthing  $6^\circ$

$A = 2.0 H$

Reduction factor  $R_s = 0.9$

Energy absorption  $E_{6^\circ} = 0.9 \times 100 = 90$  Tonne-m

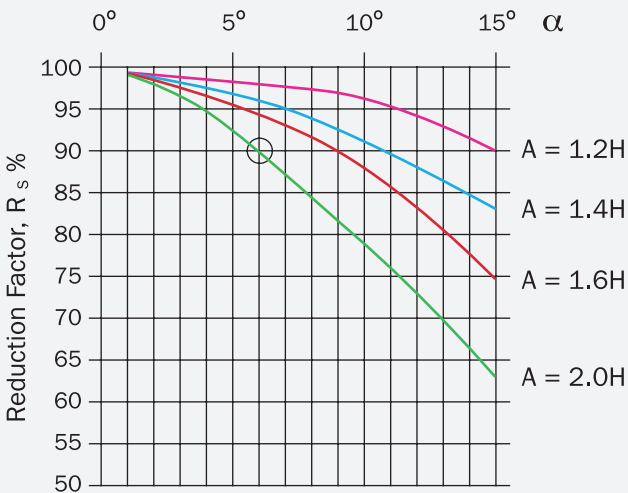
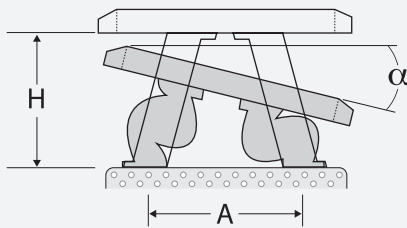

### LONGITUDINAL LOAD

Reduction factor  $R_l$  for energy absorption  $E$  is dependent on the relation between the length  $L$  and the dimension  $H$  of the fender element.

Example

2 fender elements MV 750 x 1500 B

Rated energy absorption  $E = 2 \times 14.7 = 29.4$  Tonne-m

Angular berthing  $6^\circ$

$L = 2.0 H$

Reduction factor  $R_l = 0.9$

Energy absorption  $E_{4^\circ} = 0.9 \times 29.4 = 26.5$  Tonne-m

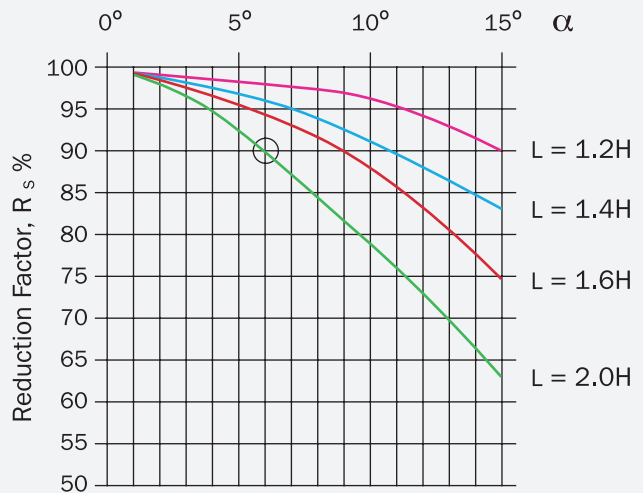
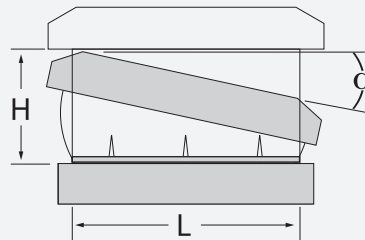

The above curves are valid for all MV-element sizes.

The characteristics consider an average rated reaction force and therefore the reaction force should always be the same as  $0^\circ$  compression.

For ratios and angles not given, one may interpolate.

In the case of both transverse and longitudinal angular berthing the factors  $R_s$  and  $R_l$  are to be multiplied to give the combined reduction factor for the compound angle.

Example

Bow radius gives transverse  $\alpha = 6^\circ$  ;  $R_s = 0.9$

Flare gives longitudinal  $\alpha = 4^\circ$  ;  $R_l = 0.9$

$R_{total} = 0.9 \times 0.9 = 0.81$

# Super Arch and Arch Fenders

## ANGLE FACTORS (AF) LONGITUDINAL LOAD

### Energy Correction Factors

L/H \ $\alpha$	0	5	6	7	8	9	10	12	15	20	25	30
0.750	1.000	0.924	0.910	0.896	0.882	0.868	0.854	0.825	0.781	0.706	0.632	0.563
1.000	1.000	0.901	0.882	0.863	0.844	0.824	0.805	0.765	0.703	0.602	0.509	0.434
1.100	1.000	0.891	0.870	0.850	0.828	0.807	0.785	0.740	0.672	0.561	0.466	0.394
1.200	1.000	0.882	0.859	0.836	0.812	0.788	0.764	0.715	0.640	0.522	0.428	0.361
1.300	1.000	0.872	0.847	0.822	0.796	0.770	0.743	0.689	0.608	0.486	0.395	0.334
1.400	1.000	0.863	0.836	0.808	0.780	0.751	0.722	0.663	0.578	0.453	0.367	0.310
1.500	1.000	0.853	0.824	0.794	0.764	0.733	0.701	0.638	0.547	0.423	0.342	0.289
1.600	1.000	0.844	0.812	0.780	0.747	0.714	0.680	0.613	0.518	0.396	0.321	0.271
1.700	1.000	0.834	0.800	0.766	0.730	0.695	0.659	0.588	0.491	0.373	0.302	0.255
1.800	1.000	0.824	0.788	0.751	0.713	0.675	0.637	0.564	0.465	0.352	0.285	0.241
1.900	1.000	0.814	0.776	0.736	0.696	0.656	0.616	0.540	0.441	0.334	0.270	0.228
2.000	1.000	0.804	0.763	0.722	0.679	0.637	0.595	0.517	0.419	0.317	0.257	0.217
3.000	1.000	0.700	0.636	0.574	0.515	0.462	0.416	0.348	0.279	0.211	0.171	0.145
4.000	1.000	0.594	0.514	0.445	0.390	0.347	0.312	0.261	0.209	0.159	0.128	0.108
5.000	1.000	0.495	0.415	0.356	0.312	0.277	0.250	0.209	0.168	0.127	0.103	0.087

### Reaction Force Correction Factors

L/H \ $\alpha$	0	5	6	7	8	9	10	12	15	20	25	30
0.750	1.000	0.873	0.866	0.862	0.862	0.864	0.867	0.878	0.896	0.921	0.926	0.907
1.000	1.000	0.863	0.862	0.865	0.870	0.878	0.886	0.903	0.922	0.921	0.817	0.777
1.100	1.000	0.862	0.863	0.869	0.876	0.885	0.895	0.912	0.926	0.907	0.824	0.708
1.200	1.000	0.862	0.866	0.873	0.883	0.893	0.903	0.919	0.927	0.882	0.767	0.649
1.300	1.000	0.863	0.869	0.879	0.890	0.900	0.911	0.924	0.923	0.849	0.709	0.600
1.400	1.000	0.865	0.873	0.885	0.897	0.908	0.917	0.927	0.914	0.806	0.658	0.556
1.500	1.000	0.867	0.878	0.891	0.903	0.914	0.922	0.927	0.899	0.759	0.614	0.519
1.600	1.000	0.871	0.883	0.897	0.909	0.919	0.925	0.924	0.879	0.712	0.576	0.487
1.700	1.000	0.874	0.888	0.903	0.915	0.923	0.927	0.917	0.854	0.670	0.542	0.458
1.800	1.000	0.878	0.893	0.908	0.919	0.926	0.927	0.908	0.823	0.632	0.512	0.433
1.900	1.000	0.882	0.899	0.913	0.923	0.927	0.924	0.894	0.789	0.599	0.485	0.410
2.000	1.000	0.887	0.903	0.917	0.925	0.927	0.920	0.878	0.752	0.569	0.461	0.389
3.000	1.000	0.922	0.927	0.912	0.876	0.819	0.747	0.624	0.501	0.379	0.307	0.260
4.000	1.000	0.919	0.876	0.795	0.699	0.622	0.561	0.468	0.376	0.285	0.230	0.195
5.000	1.000	0.858	0.745	0.639	0.560	0.498	0.448	0.375	0.301	0.228	0.184	0.156

Reaction force is the maximum generated with the compression cycle

Correction factors may be used for any size and compound of the Super Arch and Arch fender element range

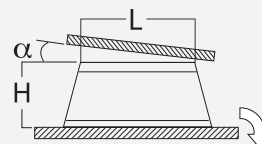

# Super Arch and Arch Fenders

## ANGLE FACTORS (AF) TRANVERSE LOAD

### Energy Correction Factors

A/H	$\beta$	DEFLECTION % AT POINT C	REACTION CORRECTION FACTOR	ENERGY CORRECTION FACTOR
3		57.5	1.000	0.999
5		57.5	0.991	0.987
6		57.5	0.986	0.973
7		57.5	0.980	0.960
8		57.5	0.974	0.947
9		57.5	0.967	0.934
10		57.5	0.959	0.922
12		57.5	0.962	0.896
15		57.5	0.986	0.857
20		57.5	1.001	0.787
25		57.5	0.999	0.716
30		57.5	0.969	0.649

- Reaction force is the maximum generated with the compression cycle
- Correction factors may be used for any size and compound of the Super Arch and Arch fender element range

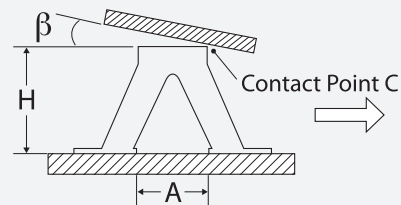

## Effect of VF and TF on fender performance: (a real life berthing example)

Let's take the example of an SCN1000 F2.5 fender to look at the impact of both TF and VF. The Performance Data (CV) is shown in the table below. We will ignore the fender manufacturing tolerance for this example:

FENDER	SCN1000 F2.5
Reaction at rated deflection	965 kN
Energy at rated deflection	540 kNm
Testing Speed	2 - 8 cm/min
Test temperature	23 ± 5°C
Compression angle	0 deg

Given a typical range of berthing velocities and temperatures at the berth, we'll explore the impact on fender performance of both of these factors.

Design and selection of fender systems will review both energy absorption and reaction force. The aim is to select a suitable fender that does not exceed the reaction force limits under normal operating conditions, whilst providing more than the minimum energy requirement.

The maximum reaction force occurs under a different set of operating conditions to the minimum energy absorption. For example, the highest reaction force will occur with the highest velocity and lowest temperature, whilst the lowest energy will occur with the slowest velocity and highest temperature.

A typical fender systems design will have the following condition:

Design berthing velocities: between 20 and 160mm/s,

Operating temperature range: between 10°C and 40°C.



# Example of correction factor calculations

## VF CALCULATION:

Assuming steady state deceleration, the compression time (t) is:

$$t = d / (f * V_d) = (0.72 \times 1000) / (0.74 \times 160) = 6.1 \text{ sec}$$

t = compression time

V<sub>d</sub> = initial berthing velocity

f = deceleration factor (peak reaction force occurs at ~ 30% deflection where there has been a deceleration due to energy absorption. f represents the factor associated with the deceleration.)

(Trelleborg Marine and Infrastructure has conducted actual high speed compression testing to validate its VFs. Information on these effects can be discussed with Trelleborg Marine and Infrastructure’s Engineers).

Based on the strain rate for this compression time, the VF is calculated to be:

**VF = 1.17 (Note: this relates ONLY to Trelleborg Marine and Infrastructure’s compound, 100% SBR based)**

## TF CALCULATION:

At operating temperature range of 10°C to 40°C

$$TF (10^\circ\text{C}) = 1.038 \text{ and } TF (40^\circ\text{C}) = 0.948.$$

(Please note this relates ONLY to Trelleborg Marine and Infrastructure’s compound, 100% SBR based)

So, under actual operating conditions, the performance will be:

Maximum Reaction Force Conditions: (@ 160 mm/s & 10°C)

$$\begin{aligned} \text{Reaction Force} &= R_{CV} \times VF \times TF \\ &= 965 \times 1.17 \times 1.038 \\ &= 1172 \text{ kN} \end{aligned}$$

Energy absorption: (@ 20 mm/s & 40°C)

$$\begin{aligned} \text{Energy Absorption} &= E_{CV} \times VF \times TF \\ &= 540 \times 1.00 \times 0.948 \text{ (VF=1, as the compression time at 20 mm/s =48 sec)} \\ &= 512 \text{ kJ} \end{aligned}$$

Therefore, under the extremes of possible operating conditions the effects of temperature and velocity are summarized below:

SCN1000 F2.5	CV PERFORMANCE (2-8 cm/min, 23°C)	VELOCITY FACTOR (VF)	TEMPERATURE FACTOR (TF)	PERFORMANCE (IN REALITY)	% CHANGE
Reaction Force	965 kN	+ 17%	+ 3.8%	1172 kN	+ 21.4%
Energy Absorption	540 kJ	0%	- 5.2%	512 kJ	- 5.2%

The same fender performs differently depending on the factors applied. The magnitude of the factor depends on the rubber compound used and size of the fender. Both have a significant effect on fender performance under real operating conditions, and subsequently, on the design and selection of the system and of the berthing structure.

It’s imperative that these factors are considered during the design of fender systems. Again, care should be taken when comparing products from different manufacturers, as factors will differ depending on the type of rubber compound used during manufacturing process.

# Fender Pitch

Fenders spaced too far apart may cause ships to hit the structure. A positive clearance (C) should always be maintained, usually between 5–15% of the uncompressed fender height (H). A minimum clearance of 300mm inclusive of bow flare is commonly specified.

- Smaller ships have smaller bow radius but usually cause smaller fender deflection.
- Clearance distances should take account of bow flare angles.
- Bow flares are greater near to the bow and stern.
- Where ship drawings are available, these should be used to estimate bow radius.

## BOW RADIUS

$$R_B \approx \frac{1}{2} \left[ \frac{B}{2} + \frac{L_{OA}^2}{8B} \right]$$

where,

$R_B$  = bow radius (m)

B = beam of vessel (m)

$L_{OA}$  = vessel length overall (m)

The bow radius formula is approximate and should be checked against actual ship dimensions where possible.

**Caution**  
Large fender spacings may work in theory but in practice a maximum spacing of 12–15 m is more realistic.

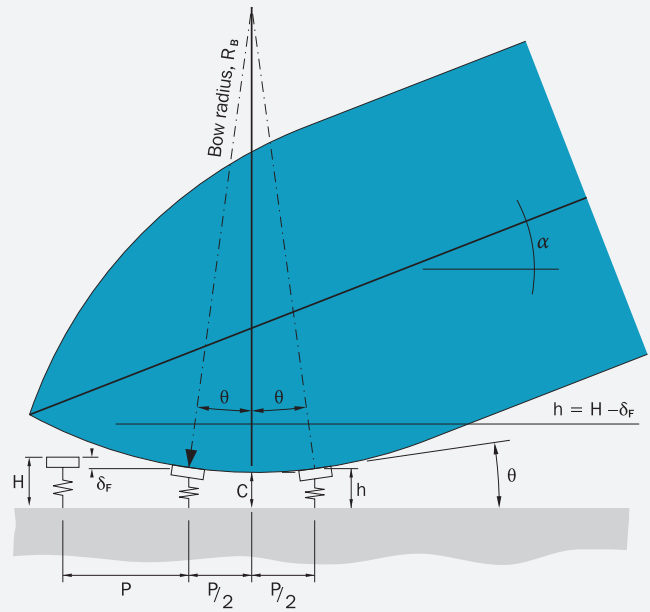

## FENDER PITCH

As a guide to suitable distance between fenders on a continuous wharf, the formula below indicates the maximum fender pitch. Small, intermediate and large vessels should be checked.

$$P \leq 2 \sqrt{R_B^2 - (R_B - h + C)^2}$$

where,

P = pitch of fender (m)

$R_B$  = bow radius (m)

h = fender projection when compressed, measured at centerline of fender

$\alpha$  = berthing angle

C = clearance between vessel and dock (C should be 5–15% of the undeflected fender projection, including panel) (m)

$\theta$  = hull contact angle with fender

According to BS 6349, it is also recommended that the fender spacing does not exceed  $0.15 \times LS$ , where LS is the length of the smallest ship.

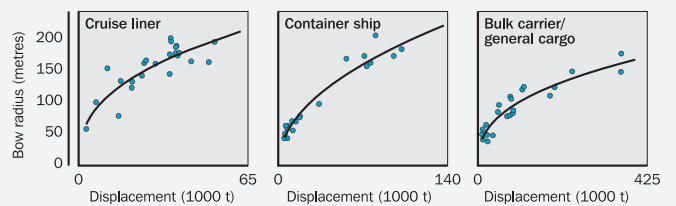

# Multiple Contact Cases

## 3-fender contact

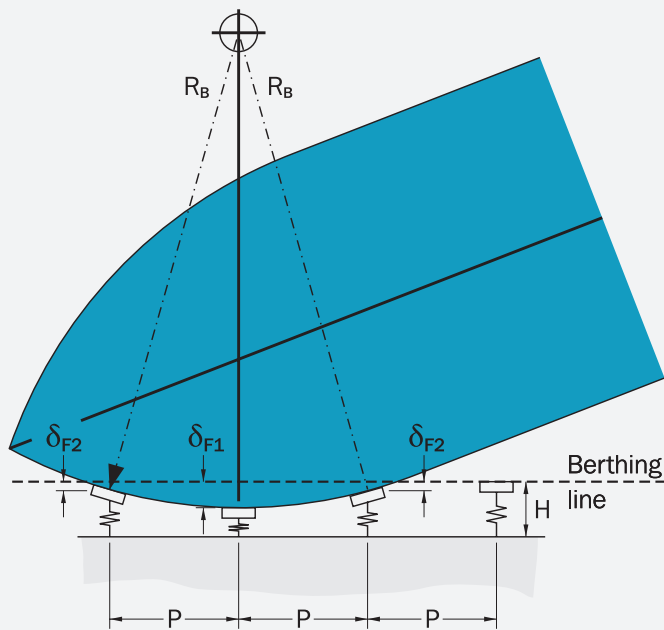

- Energy absorbed by three (or more) fenders
- Larger fender deflection likely
- Bow flare is important
- 1-fender contact also possible for ships with small bow radius

## 2-fender contact

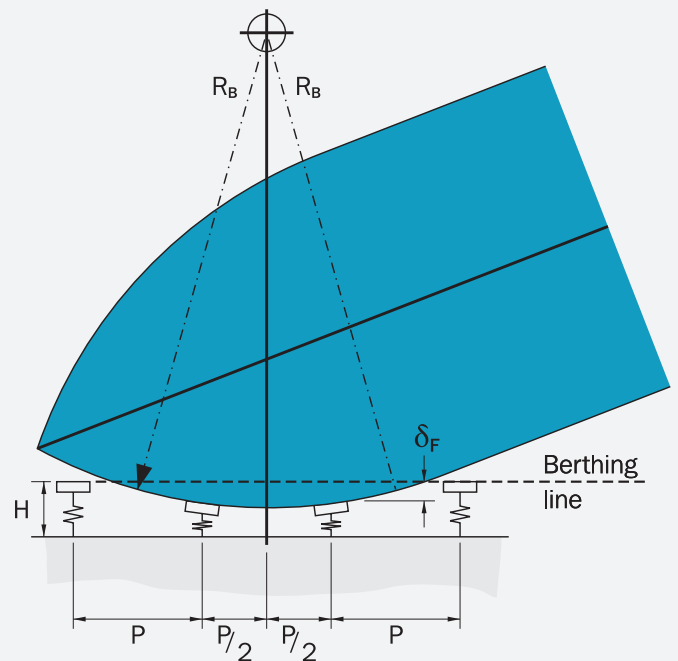

- Energy divided over 2 (or more) fenders
- Smaller fender deflections
- Greater total reaction into structure
- Clearance depends on bow radius and bow flare

## ANGULAR BERTHING

The berthing angle between the fender and the ship's hull may result in some loss of energy absorption. Angular berthing means the horizontal and/or vertical angle between the ship's hull and

the berthing structure at the point of contact.

There are three possible conditions for the effects of angular berthing: flare, bow radius and dolphin.

### Flare

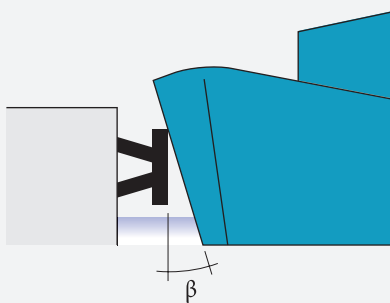

### Bow radius

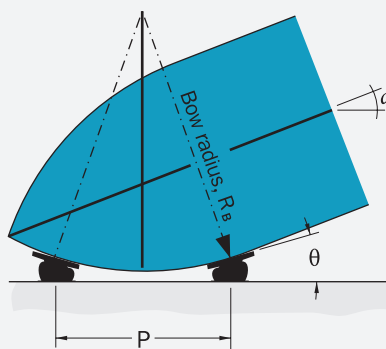

$$\sin \theta = \frac{P}{2R_B} \quad \text{where } R_B = \text{bow radius}$$

### Dolphin

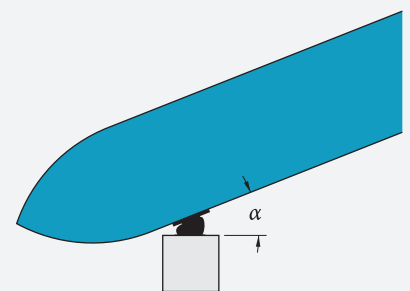

# Fender Accessories



Fender panels are just as important as the rubber units on high performance systems.

Some fender systems need chains to help support heavy components or to control the deflection and shear during impact.

Compatible accessories like shackles, brackets and U-anchors of high standards are available with every fender systems.

# Fender Panel Design

## FACTORS AFFECTING FENDER PANEL DESIGN

Fender panels are used to distribute reaction forces into the hulls of berthing vessels. The panel design should consider many factors including:

### 3 design cases

Full-face contact

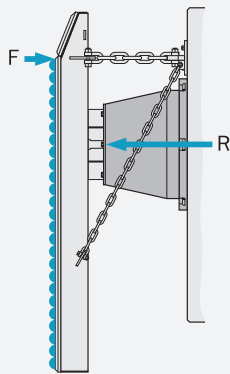

Low-level impact

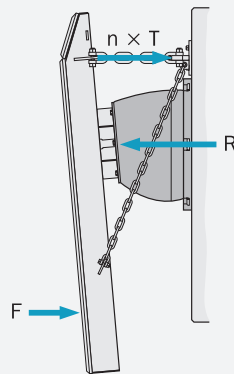

Double contact

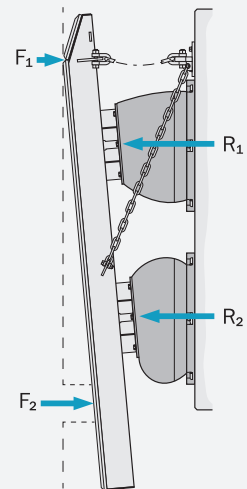

- Hull pressures and tidal range
- Lead-in bevels and chamfers
- Bending moment and shear
- Local buckling
- Limit state load factors
- Steel grade

- Permissible stresses
- Weld sizes and types
- Effects of fatigue and cyclic loads
- Pressure test method
- Rubber fender connections
- UHMW-PE attachment

- Chain connections
- Lifting points
- Paint systems
- Corrosion allowance
- Maintenance and service life

## Fender panels

- 1 Closed box steel structure
- 2 Internal structural members
- 3 Blind boss fender connections
- 4 Shot blasted steel (SA2.5)
- 5 C5M modified epoxy paint\*
- 6 Polyurethane topcoat (RAL5005 blue)†
- 7 Studs for UHMW-PE face pads
- 8 Chain brackets
- 9 Lifting points
- 10 Lead-in bevels and chamfers\*

\* Other options available † Alternative colors on request

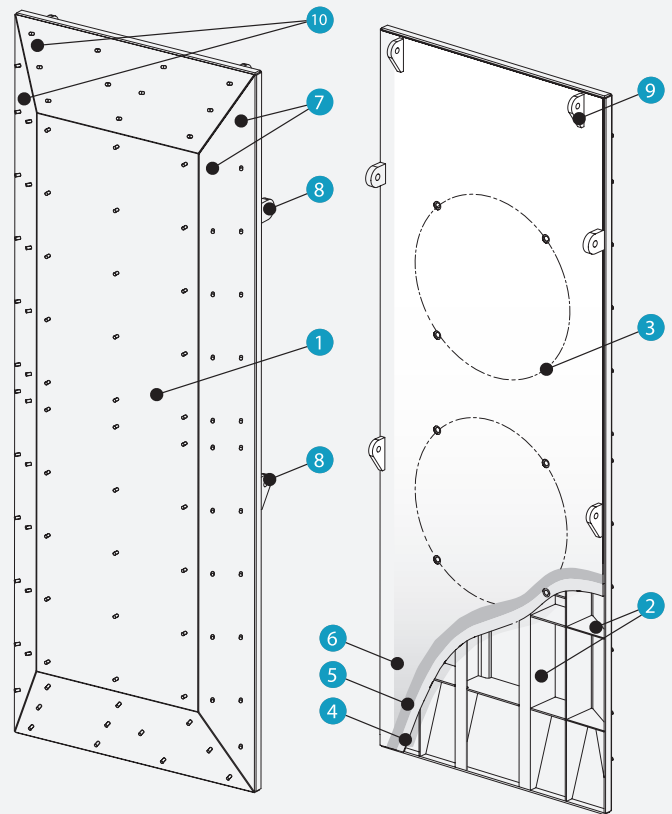

## Steel properties

STANDARD	GRADE	YIELD STRENGTH (min)		TENSILE STRENGTH (min)		TEST TEMPERATURE OF (V-NOTCHED) CHARPY IMPACT TEST	
		N/mm <sup>2</sup>	psi	N/mm <sup>2</sup>	psi	°C	°F
GB/T 700	Q235B	235	34000	375	54000	20	68
	Q275B	275	40000	490	71000	20	68
GB/T 1591	Q345B	345	50000	470	68000	20	68
	Q345C	345	50000	470	68000	0	32
EN 10025	S235JR (1.0038)	235	34000	360	52000	20	68
	S275JR (1.0044)	275	40000	420	61000	20	68
	S355J2 (1.0570)	355	51000	510	74000	-20	-4
	S355J0 (1.0553)	355	51000	510	74000	0	32
JIS G-3101	SS400	235	34000	402	58000	0	32
	SS490	275	40000	402	58000	0	32
	SM490	314	46000	490	71000	0	32
ASTM	A-36	250	36000	400	58000	0	32
	A-572	345	50000	450	65000	0	32

The national standards of France and Germany have been replaced by EN 10025. In the UK, BS4360 has been replaced by BS EN 10025. The table above is for guidance only and is not comprehensive. Actual specifications should be consulted in all cases for the full specifications of steel grades listed and other similar grades.

## Steel thickness

(in accordance with PIANC 2002)

Exposed both faces	≥ 12
Exposed one face	≥ 9
Internal (not exposed)	≥ 8

[Units: mm]

Corresponding minimum panel thickness will be 140 – 160 mm (excluding UHMW-PE face pads) and often much greater.

## Typical panel weights

Light duty	200 – 250
Medium duty	250 – 300
Heavy duty	300 – 400
Extreme duty	≥ 400

[Units: kg/m<sup>2</sup>]

# Hull Pressures and Beltings

## HULL PRESSURES

Allowable hull pressures depend on hull plate thickness and frame spacing. These vary according to the type of ship. Refer to the table on the right for PIANC's guidelines on hull pressures.

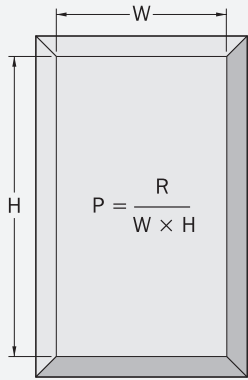

P = average hull pressure (kN/m<sup>2</sup>)  
 R = total fender reaction (kN)  
 W = panel width, excluding bevels (m)  
 H = panel height, excluding bevels (m)

## BELTINGS

Most ships have beltings (sometimes called belts or strakes). These come in many shapes and sizes – some are well-designed, others can be poorly maintained or modified.

Care is needed when designing fender panels to cope with beltings and prevent snagging or catching which may damage the system.

Belting line loads exert crushing forces on the fender panel which must be considered in the structural design.

APPLICATION	VESSELS	BELTING LOAD (kN/m)
Light duty	Aluminium hulls	150 – 300
Medium duty	Container	500 – 1,000
Heavy duty	RoRo / Cruise	1,000 – 1,500

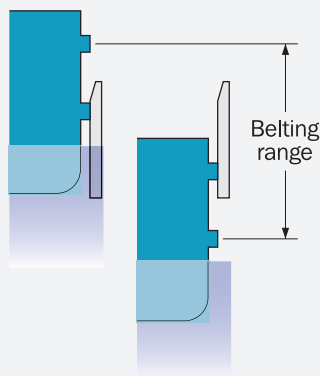

Belting range is often greater than tidal range due to ship design, heave, roll, and changes in draft.

VESSEL TYPE	SIZE/CLASS	HULL PRESSURE (kN/m <sup>2</sup> )
Container ships	< 1,000 teu (1st/2nd generation)	< 400
	< 3,000 teu (3rd generation)	< 300
	< 8,000 teu (4th generation)	< 250
	> 8,000 teu (5th/6th generation)	< 200
General cargo	≤ 20,000 DWT	400–700
	> 20,000 DWT	< 400
Oil tankers	≤ 20,000 DWT	< 250
	> 20,000 DWT	< 300
Gas carriers	LNG/LPG	150–200
Bulk carriers		< 200
RoRo		Usually fitted with beltings (strakes)
Passenger/cruise		
SWATH		

Source: PIANC 2002; Table 4.4.1

### Belting types

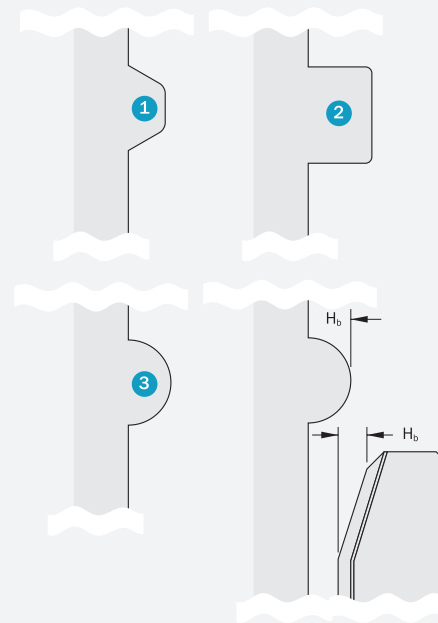

- ① ② Common on RoRo/Cruise ships. Projection 200 – 400 mm (typical).
- ② Internal structural members
- ③ Common on LNG/Oil tankers, barges, offshore supply vessels and some container ships. Projection 100 – 250 mm (typical).

# Friction and Chain Design

## FRICTION

Friction has a large influence on the fender systems' design, particularly for restraint chains. Low friction facing materials (UHMW-PE) are often used to reduce friction. Other materials, like polyurethanes (PU) used for the skin of foam fenders, have lower friction coefficients than rubber against steel or concrete. The table can be used as a guide to typical design values. Friction coefficients may vary due to wet or dry conditions, local temperatures, static and dynamic load cases, as well as surface roughness.

## CHAIN DESIGN

Chains can be used to restrain the movements of fenders during compression or to support static loads. Chains may serve four main functions:

- Weight chains support the steel panel and prevent excessive drooping of the system. They may also resist vertical shear forces caused by ship movements or changing draft.
- Shear chains resist horizontal forces caused during longitudinal approaches or warping operations.
- Tension chains restrict tension on the fender rubber. Correct location can optimize the deflection geometry.
- Uplift chains prevent vertical shear forces in conjunction with weight chains. These are often specified for exposed offshore berths with large wave movements.
- Detension chains are a temporary set of chains used in conjunction with a hydraulic pull cylinder to assist with slackening the operational chains during maintenance changeout procedures.
- Rope guard chains are sometimes specified to prevent mooring lines from getting caught behind fender panels particularly on panels with no top tension chains.
- Keep chains are used to moor floating fenders or to prevent loss of fixed fenders in the event of accidents.

## Typical friction design values

MATERIALS		FRICTION COEFFICIENT ( $\mu$ )
UHMW-PE	Steel	0.2
HD-PE	Steel	0.3
Polyurethane	Steel	0.4
Rubber	Steel	0.7
Timber	Steel	0.4
Steel	Steel	0.5

## Factors to be considered when designing fender chains:

- Corrosion reduces link diameter and weakens the chain
- Corrosion allowances and periodic replacement should be factored in
- A 'weak link' in the chain system is desirable to prevent damage to more costly components in an accident



# Friction and Chain Design

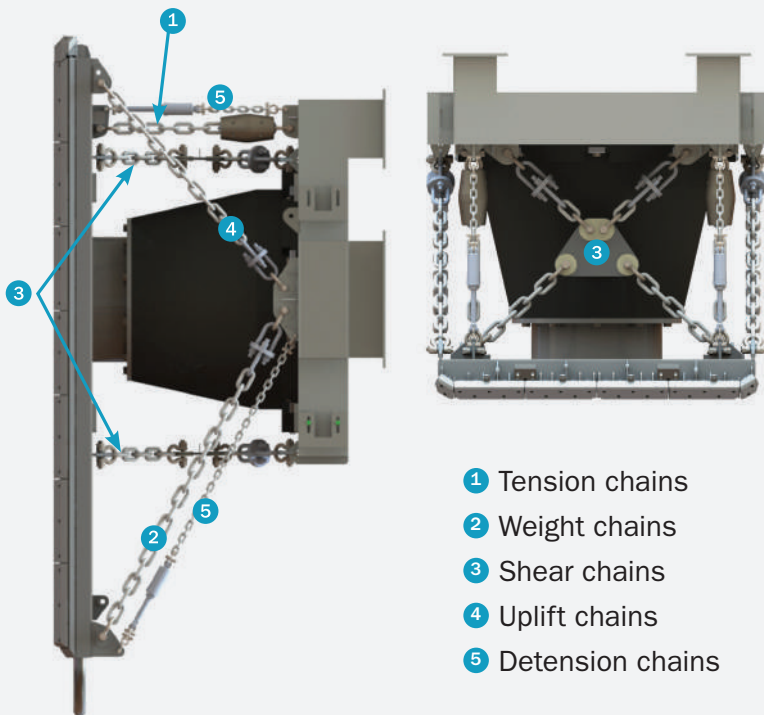

- 1 Tension chains
- 2 Weight chains
- 3 Shear chains
- 4 Uplift chains
- 5 Detension chains

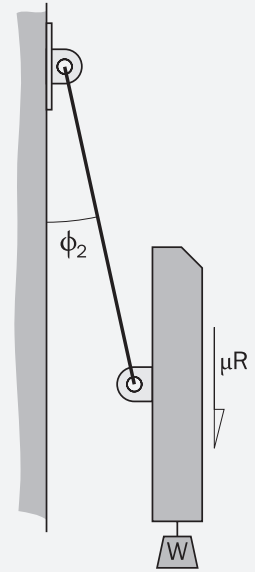

Note: Selection of chains depends on project requirements. Please consult Trelleborg Marine and Infrastructure.

$$\phi_1 = a \sin \left[ \frac{H_1}{L_c} \right] \text{ or } H_1 = L_c \cdot \sin \phi_1$$

$$H_2 = H_1 - \delta_F$$

$$\phi_2 = a \sin \left[ \frac{H_2}{L_c} \right] \text{ or } \phi_2 = a \sin \left[ \frac{H_1 - \delta_F}{L_c} \right]$$

$$SWL = \frac{(\mu \cdot (\Sigma R)) + W}{9.81 \cdot n \cdot \cos \phi_2}$$

$$MBL = F_c \cdot SWL$$

where,

- $\phi_1$  = Static angle of chain (degrees)
- $H_1$  = Static offset between brackets (m)
- $L_c$  = Bearing length of chain (m)
- $H_2$  = Dynamic offset between brackets at F (m)
- $\delta_F$  = Fender compression (m)
- $\phi_2$  = Dynamic angle of chain (degrees)
- SWL = Safe Working Load of chain (tonne)
- $\mu$  = 0.2 Friction coefficient of the face pad material, i.e. UHMW-PE facings
- $\Sigma R$  = Combined reaction of all rubber fenders (kN)
- $n$  = Number of chains acting together
- MBL = Minimum Breaking Load of chain (tonne)
- $F_c$  = Factor of safety = 2~3 (typically)

# UHMW-PE

The contact face of a fender panel helps to determine the lifetime maintenance costs of a fender installation. UHMW-PE is the best material available for such applications. It uniquely combines low friction, impact strength, non-marking characteristics and resistance to wear, temperature extremes, seawater and marine borers. UHMW-PE is molded into plates at extremely high pressure and is a totally homogeneous material which is available in many sizes and thicknesses. These plates can be cut, machined and drilled to suit any type of panel or shield.

## Features

- ▮ Very low friction coefficient
- ▮ Excellent abrasion resistance
- ▮ UV and ozone resistant
- ▮ Does not rot, split or crack
- ▮ 100% recyclable

## Applications

- ▮ Fender panel (frame) face pads
- ▮ Rubbing strips
- ▮ V-fender shields
- ▮ Lock entrance and wall protection
- ▮ Bridge buttress protection
- ▮ Beltings on workboats

## PHYSICAL PROPERTIES OF UHMW-PE PADS

PROPERTY	TEST METHOD	UNIT	TYPICAL VALUE	
			VIRGIN	REGENERATED *
Density	ISO 1183-1	g/cm <sup>3</sup>	0.920 – 0.945	0.920 – 0.945
Dynamic friction (PE-Steel)	Pm = 1N/mm <sup>2</sup> V = 10m/min	–	0.15	0.15
Mass Melt-flow rate (MFI)	ISO 1133/ ASTM D1238	g/10 min	0 - 0.1	0 - 0.1
% Crystallinity (2nd heating cycle)	ISO 11357-3/ ASTM D3418	%	50 ± 5 (Avg. of two samples. The variation between the samples should be less than 5%)	50 ± 5 (Avg. of two samples. The variation between the samples should be less than 5%)
Peak melting temperature	ISO 11357-3/ ASTM D3418	°C	135 ± 4 (Avg. of two samples. The variation between the samples should be less than 5%)	135 ± 4 (Avg. of two samples. The variation between the samples should be less than 5%)
Abrasion resistance (sand slurry test)	Sample preparation: ISO 11542 Testing: ISO 15527 (modified test conditions) Reference specimen: VN: 2300 ml/g	ml/g	90 - 140	90 - 140
Double notch Charpy impact strength	Sample preparation: ISO 11542-2 Testing: ISO 11542-2 ASTM D4020-11	KJ/sq.m	90 - 260 (two molded samples, (<5% variation in results))	90 - 260 (two molded samples, (<5% variation in results))
Operating temperature	–	°C	–80 to +80	–80 to +80
Thermal expansion	DIN 53752	K <sup>-1</sup>	≈ 2 × 10 <sup>-4</sup>	≈ 2 × 10 <sup>-4</sup>

Sample frequency: 1 samples/ molding  
Size: cut from the actual product (100mmW x 100mmL x min.10mm thick)

\* Yield strength, tensile strength and elongation at break are lower than virgin material.

# UHMW-PE

## WEAR ALLOWANCES

APPLICATION	t (mm)	W* (mm)	BOLT
Light duty	30	3 – 5	M16
Medium duty	40	7 – 10	M16 – M20
	50	10 – 15	
Heavy duty	60	15 – 19	M24 – M30
	70	18 – 25	
	80	22 – 32	
Extreme duty	90	25 – 36	M30 – M36
	100	28 – 40	

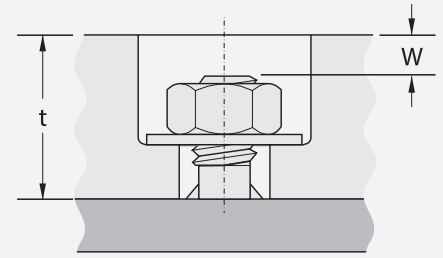

[Units: mm]

\* Where allowances are typical values, actual wear allowance may vary due to fixing detail. Small increases in facing thickness can greatly extend service life for minimal extra cost.

## Typical dimensions

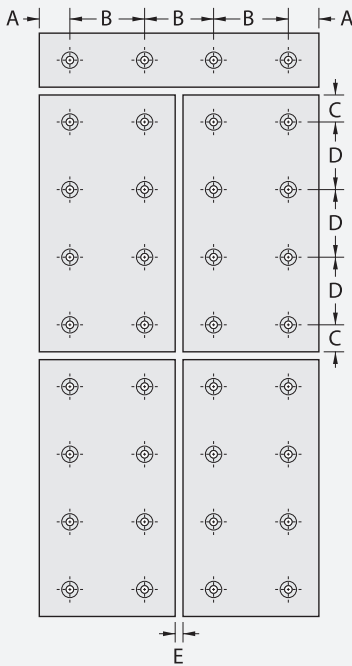

A	45–80
B	250–350
C	45–80
D	300–450
E	5–10

[Units: mm]

Dimensions will depend on pad thickness and application.

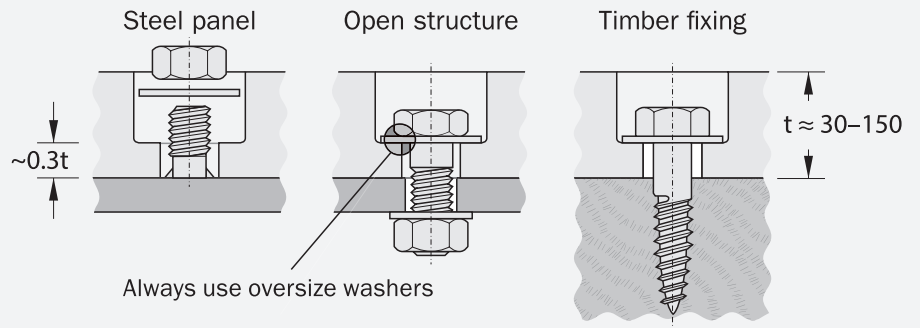

## Large pads vs small pads

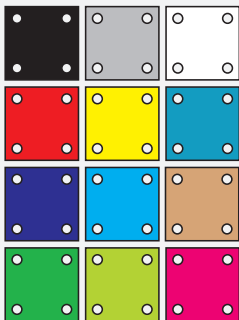

The standard color is black, but UHMW-PE is available in many other colors if required.

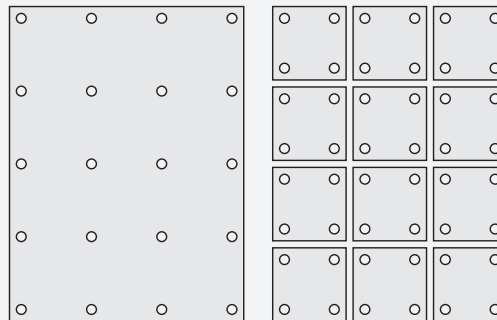

Larger pads are usually more robust but smaller pads are easier and cheaper to replace.

## Corrosion Prevention

Fenders are usually installed in corrosive environments, sometimes made worse by high temperature and humidity. Corrosion of fender accessories can be reduced with specialist paint coatings, by galvanizing or with selective use of stainless steels.

### PAINT COATINGS

ISO EN 12944-5:2007 is a widely used international standard defining the durability of corrosion protection systems in various environments. The C5-M class applies to marine coastal, offshore and high salinity locations and is considered to be the most applicable to fenders.

The life expectancy or 'durability' of coatings is divided into three categories which estimate the time to first major maintenance:

Paint coatings and galvanizing have a finite life. Coating must be reapplied at intervals during the life of the fender. Galvanized components like chains or bolts may need periodic re-galvanizing or replacement. Stainless steels should be carefully selected for their performance in seawater.

Low	2 – 5 years
Medium	5 – 15 years
High	> 15 years

Durability range is not a guarantee. It is to help operators estimate sensible maintenance times.

The table gives some typical C5-M class paint systems based on ISO EN 12944-5:2007 standard which provides high durability in marine environments. Note that coal tar epoxy paints are not available in some countries.

PAINT SYSTEM	SURFACE PREPARATION	PRIMING COAT(S)				SUBSEQUENT COAT(S)		NDFT	EXPECTED DURABILITY (C5-M CORROSION)
		BINDER	PRIMER	No. COATS	NDFT	BINDER	No. COATS		
A5M.02	Sa 2.5	EP, PUR	Misc.	1	80	EP, PUR	3 – 4	320	High (>15y)
A5M.04	Sa 2.5	EP, PUR	Misc.	1	250	EP, PUR	2	500	High (>15y)
A5M.06	Sa 2.5	EP, PUR, ESI	ZN ('R)	1	60	EP, PUR	4 – 5	320	High (>15y)
A5M.08	Sa 2.5	EPC	Misc.	1	100	EPC	3	300	Medium (5-15y)

Sa 2.5 is defined in ISO 8501-1

NDFT = Nominal dry film thickness

Zn (R) = Zinc rich primer

Misc = miscellaneous types of anticorrosive pigments

EP = 2-pack epoxy

PUR = 1-pack or 2-pack polyurethane

ESI = 1-pack or 2-pack ethyl silicate

EPC = 2-pack epoxy combination

### DESIGN CONSIDERATIONS

Other paint systems may also satisfy the C5-M requirements but in choosing any coating the designer should carefully consider the following:

- Corrosion protection systems are not a substitute for poor design details such as re-entrant shapes and corrosion traps
- Minimum dry film thickness >80% of NDFT (typical)
- Maximum film thickness <3 × NDFT (typical)
- Local legislation on emission of solvents or health & safety factors
- Application temperatures, drying and handling times
- Maximum over-coating times
- Local conditions including humidity or contaminants

# Corrosion prevention

## GALVANIZING

Hot-dip galvanizing is the process of coating steel parts with a zinc layer by passing the component through a bath of molten zinc. When exposed to sea water the zinc acts as an anodic reservoir which protects the steel underneath. Once the zinc is depleted the steel will begin to corrode and lose strength.

Galvanizing thickness can be increased by:

- Shot blasting the components before dipping
- Pickling the components in acid
- Double dipping the components (only suitable for some steel grades)

Spin galvanizing is used for threaded components which are immersed in molten zinc then immediately centrifuged to remove any excess zinc and clear the threads. Spin galvanized coatings are thinner than hot dip galvanized coatings and will not last as long in marine environments.

Typical galvanizing thicknesses:

Hot dip galvanizing	85 µm
Spin galvanizing	40 µm

## STAINLESS STEELS

### Pitting Resistance

Stainless steel performance in seawater varies according to pitting resistance. Chemical composition – especially Chromium (Cr), Molybdenum (Mo) and Nitrogen (N) content – is a major factor in pitting resistance.

The pitting resistance equivalent number (PREN) is a theoretical way to compare stainless steel grades. The most common formula for PREN is:

$$PREN = Cr + 3.3Mo + 16N$$

Cr and Mo are major cost factors for stainless steel. A high PREN material will usually last longer but cost more.

### Galling

Galling or 'cold welding' affects threaded stainless steel components including nuts, bolts and anchors. The protective oxide layer of the stainless steel gets scraped off during tightening causing high local friction and welding of the threads. After galling, seized fasteners cannot be further tightened or removed and usually need to be cut out and replaced.

To avoid this problem, always apply anti-galling compounds to threads before assembly. If these are unavailable then molybdenum disulfide or PTFE based lubricants can be used.

GRADE	COMMON NAME	TYPE	Cr (%)	Mo (%)	N (%)	PREN	COMMENTS
1.4501	Zeron 100	Duplex	24.0–26.0	3.0–4.0	0.2–0.3	37.1–44.0	used where very long service life is needed
1.4462	SAF 2205	Duplex	21.0–23.0	2.5–3.5	0.1–0.22	30.9–38.1	
1.4401	316S31	Austenitic	16.5–18.5	2.0–2.5	0–0.11	23.1–28.5	widely used for fender fixings
1.4301	304	Austenitic	17.0–19.5	–	0–0.11	17.0–21.3	unsuitable for most fender applications
1.4003	3CR12	Ferritic	10.5–12.5	–	0–0.03	10.5–13.0	

Percentages of Cr, Mo and N are typical mid-range values and may differ within permissible limits for each grade.

Source: British Stainless Steel Association ([www.bssa.org.uk](http://www.bssa.org.uk)).

# Fender Performance Testing



Testing is carried out in two stages: to prove behavior of the generic fender type and to confirm that performance of fenders made for each project meet the required performances.

Trelleborg is committed to providing high quality products. Consistency and performance are routinely checked in accordance with the latest procedures and test protocols.

PIANC has introduced new methods and procedures for testing the performance of solid rubber fenders, allowing for real world operating conditions, in their document 'Guidelines for the Design of Fender Systems: 2002: Appendix A'.

Many of Trelleborg's most popular fenders are manufactured in accordance with PIANC's guidelines. This brings the following benefits:

- Proven product quality
- Tests simulate real operating conditions
- Longer service life
- Lower maintenance
- Greater reliability
- Reduced lifetime costs
- Manufacturer's commitment
- Excludes unsafe 'copy' and 'fake' fenders
- Simplifies contract specifications

## Testing Procedures

Trelleborg's testing procedures for 'solid-type' rubber fenders comply with PIANC 'Guidelines for the Design of Fender Systems: 2002: Appendix A: Section 6: Verification/Quality Assurance Testing'.

### TEST APPARATUS AND MEASURING EQUIPMENT

The test apparatus shall be under controlled conditions and equipped with calibrated load cells or pressure transducer and linear transducer(s) for measuring displacement to provide continuous real-time monitoring of fender performance.

The load cell system or the pressure transducer has to be capable of recording and storing data at intervals of 0.01 H – 0.05 H where H is the nominal height of the fender.

Validity of calibration certificates within one year:

- Ensures calibration certificate for pressure transducer is valid.
- Ensures calibration certificate for linear transducer is valid.
- Ensures certificate, verifying the accuracy of test press against pressure transducer, is valid.
- Ensures calibration certificate for load cells, if applicable, is valid.

Where testing of cylindrical, arch, element and similar fenders over 2.0 m long is required, please contact your local office to discuss exact requirements.

#### Notes

- 1 Standard PIANC Verification Testing of 10% of fender order (rounded up to the nearest unit)
- 2 A single break-in deflection is recommended on fenders for load-sensitive structures with reaction of 100t or more.
- 3 Additional tests, 2nd / 3rd party witnessing, recommended break-in deflection and special procedure will incur extra charges.
- 4 All measuring equipment shall be calibrated and certified accurate to within  $\pm 1\%$  in accordance with ISO or equivalent JIS or ASTM requirements. Calibration shall be traceable to national/international standard and shall be performed annually by an accredited third party organization.
- 5 Non-compliant units will be clearly marked and segregated.

The Constant Velocity (CV) slow speed test method is used for SCN, SCK, UE, AN, ANP, MV, MI and Cylindrical Fenders.

### TEST PROCEDURE – METHOD CV

The fender stabilization time shall not be less than  $20 \times t^{1.5}$  days rounded to the next full day (where 't' = highest rubber thickness, in meters) before testing is permitted.

- a) Check that the fender is given a unique serial number and record it.
- b) Measure the temperature of the fender and record it.
- c) Place the fender at the center of the testing platen.
- d) Compress the fender until the maximum or 110% of the catalogue nominal reaction force is reached three times.
- e) Remove the load from the fender and allow it to recover for a minimum of 1 hour and a maximum of 24 hours.
- f) Compress the fender once at constant 2 to 8 cm/min deflection.
- g) Record the reaction force at every 2 mm deflection.
- h) Stop compressing when 110% of rated reaction force or maximum specified reaction force is reached.
- i) Remove the fender from the press.
- j) Check the fender for any physical defects.
- k) Retrieve the raw data and apply temperature factor, if required
- l) Calculate the energy absorption
- m) Plot a graph with the reaction force and energy absorption versus deflection data.

# Testing Procedures

## REPORTING

The report shall be printed on Trelleborg letterhead with the following information:

- a) Customer name,
- b) Project name,
- c) Customer PO reference,
- d) Factory sales order reference,
- e) Description of the fender, type and size
- f) Fender E grade,
- g) Quantity of the order,
- h) Serial number of the fender tested,
- i) Test date,
- j) Fender temperature,
- k) Test speed,
- l) Test angle
- m) Test method – CV
- n) RF and EA specified,
- o) Maximum RF and minimum EA allowed,
- p) Name of test supervisor,
- q) Name and signature of Quality Manager,
- r) Name and signature of client representative, if applicable,
- s) Name and signature of the 3rd party surveyor, if applicable,
- t) Company stamp of the 3rd party, if applicable,
- u) Data of reaction force and energy absorption at every 5% deflection after applying of TF, if applicable,
- v) Graph of reaction force and energy absorption versus deflection
- w) Result of the test – Passed or Failed

Our fender systems are subjected to rigorous test protocols at all stages of manufacture. Quality control testing is carried out on rubber compound, steel and UHMW-PE materials.

We also carry out full scale tests on finished products in the factory, including PIANC guidelines on angular compression and durability testing.

It is our commitment to ensure that all products have undergone extensive testing. All our products are tested according to industry guidelines, internal procedures and to the specification they are designed for.





## Performance Data (CV)

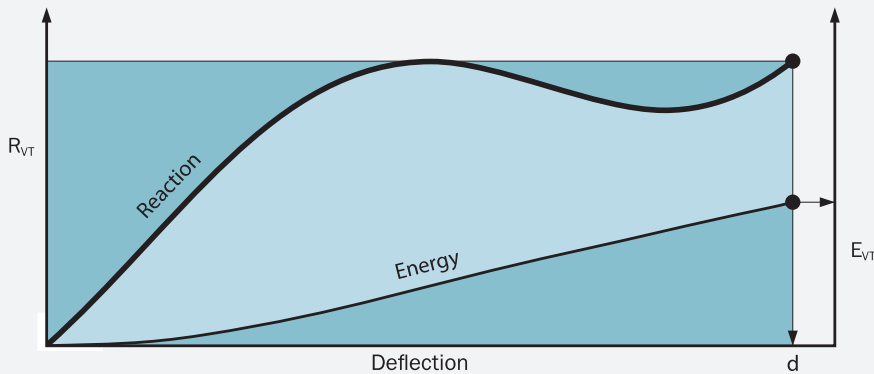

CV testing conditions:

- $23 \pm 5^\circ\text{C}$  temperature
- $0^\circ$  compression angle
- 2 - 8 cm/min constant velocity

## CORRECTION FACTORS ON PERFORMANCE TESTS

**Impact speed\***            **0.001m/s to 0.5m/s**

Rubber is a visco-elastic material, meaning that reaction and energy are affected by the speed of compression. The effect of compression speed on some rubbers is higher compared to others. Please refer to VF section (page 31).

**Temperature\***             **$-30^\circ\text{C}$  to  $+50^\circ\text{C}$**

At low temperatures rubber becomes stiffer, which increases reaction forces. At higher temperatures rubber softens, which reduces energy absorption. CV reported at  $23 \pm 5$  deg C.

**Compression angle\***     **$0^\circ$  to  $20^\circ$**

Most fenders lose some energy absorption capacity when compressed at an angle. CV is reported at  $0^\circ$ .

**Durability**                **3000 cycles minimum**

To prove durability, fenders should be subjected to a long-term fatigue test of at least 3000 cycles to rated deflection without failure.

To be meaningful, Type Approval testing should be monitored and witnessed by accredited third-party inspectors such as Germanischer Lloyd. After successful Type Approval testing, the manufacturer should publish Rated Performance Data (RPD) for their fenders along with correction factor tables for different velocities, temperatures and compression angles.

\* Velocity factor, temperature factor and angle factor must be considered during the design stage of a fender system.

## Pass Criteria

Verification testing (or quality control testing) is carried out to prove the performance of fenders for each project in accordance with catalogue CV or other customer-specified values. Samples from the project (usually 10% of the total quantity in

each size and grade) are tested. Results obtained are adjusted if necessary for each project using the correction factor tables for initial impact speed and temperature.

### PASSING CRITERIA

The fender passes verification testing if it meets the following conditions:

a) There is no visual evidence of bond failure or splits on the surface of the fender.

b)  $R_{VT} \leq R_{CV} \times 1.1 \times TF$  (or maximum  $R_{CV} \times TF$ , as specified)

$E_{VT} \geq E_{CV} \times 0.9 \times TF$  (or minimum  $E_{CV} \times TF$ , as specified)

Where,

$R_{VT}$  = Reaction Force from verification testing

$R_{CV}$  = CV Performance Data, Reaction

$E_{VT}$  = Energy Absorption from verification testing

$E_{CV}$  = CV Performance Data, Energy

TF = Temperature Factor when test sample is above or below  $23^{\circ}\text{C} \pm 5^{\circ}\text{C}$

The following formula is applicable for MV/MI fenders.

$R_{VT} \leq R_{RPD} \times 1.1 \times 0.74 \times TF$  or maximum  $R_{RPD} \times 0.74 \times TF$ , as specified

$E_{VT} \geq E_{RPD} \times 0.9 \times 0.74 \times TF$  or minimum  $E_{RPD} \times 0.74 \times TF$ , as specified

Velocity factor for DV to CV is 0.74 or CV to DV is 1.35

c) Deflection is not a pass/fail criteria, please refer to PIANC:2002 page 49 point 6.1.2

# Pass Criteria

## REACTION FORCE PASS CRITERIA

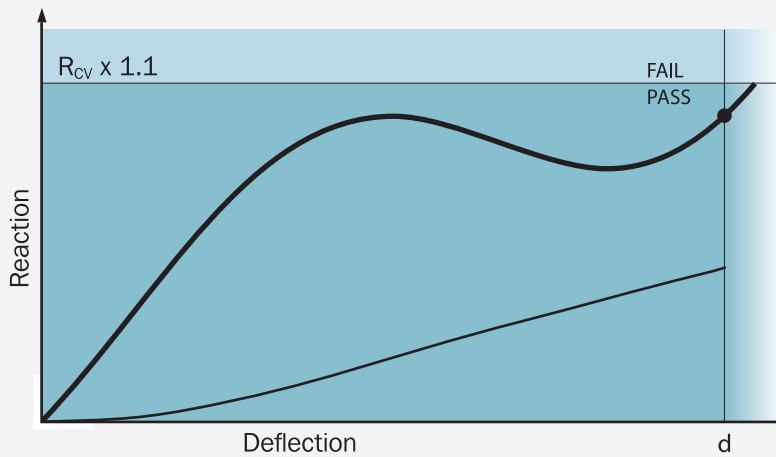

$$R_{VT} \leq R_{CV} \times TF \times 1.1$$

Assuming a +10% manufacturing tolerance on reaction.

## Energy absorption pass criteria

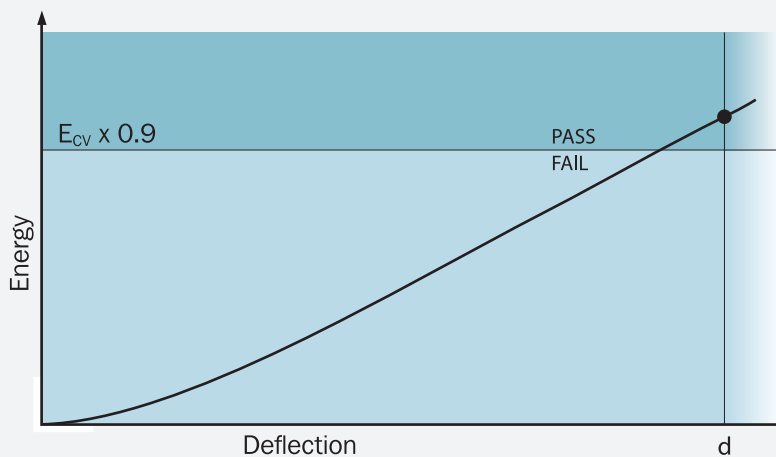

$$E_{VT} \geq E_{CV} \times TF \times 0.9$$

Assuming a -10% manufacturing tolerance on energy.

where,

$R_{VT}$  = reaction from verification testing

$R_{CV}$  = CV performance data, reaction

$E_{VT}$  = energy from verification testing

$E_{CV}$  = CV performance data, energy

TF = temperature factor for actual test temperature



ELONGATION AT BREAK

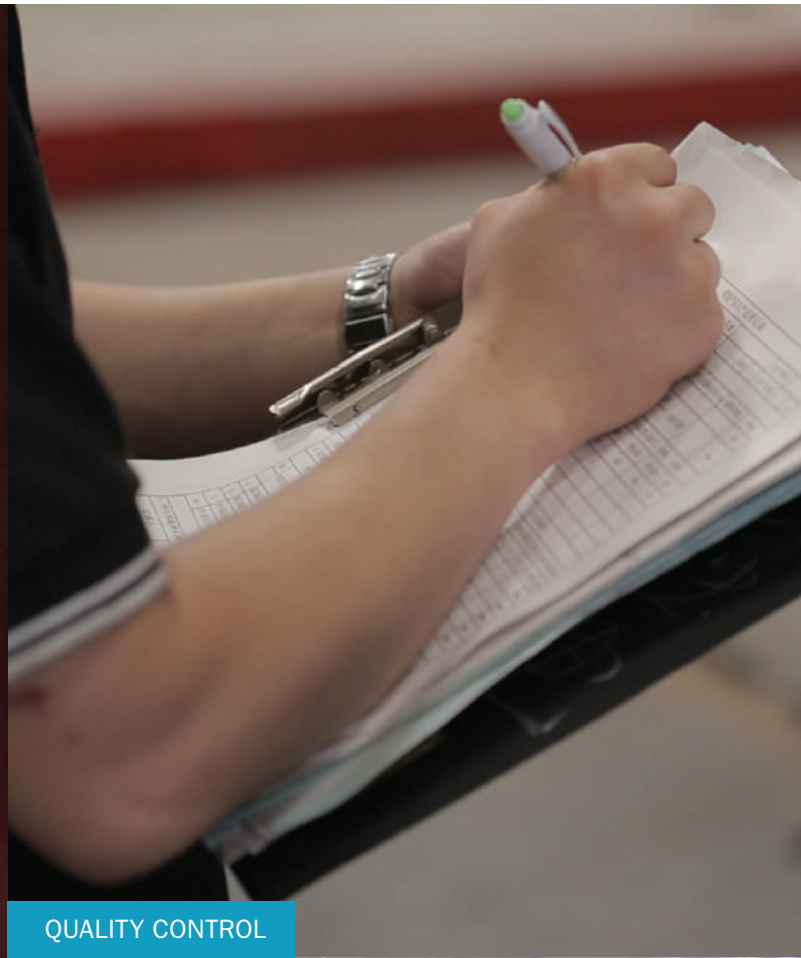

QUALITY CONTROL



DYNAMIC FATIGUE TESTING



FULL FENDER TESTING

# Other Design Considerations

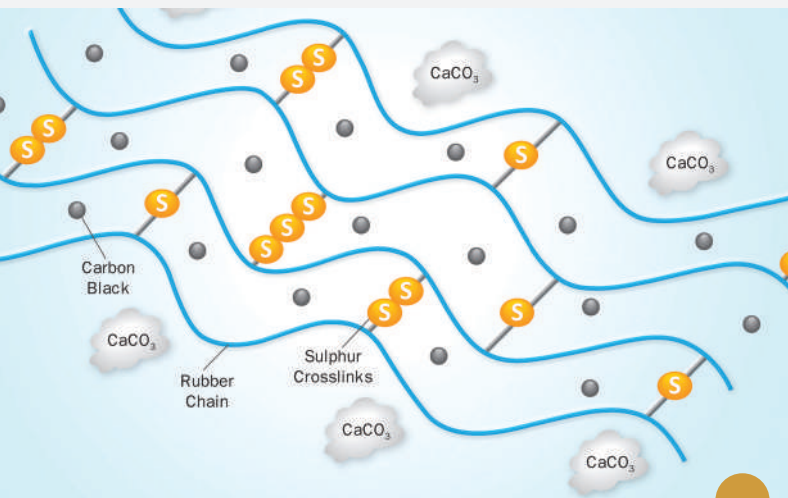

Rubber is a class of polymeric material which has the property of elasticity.

- ▮ Rubber is made up of long chains of atoms, mainly carbon, hydrogen and oxygen, which have a degree of crosslinking with their neighboring chains.
- ▮ It is these crosslinking bonds that pull the elastomer back into shape when the deforming force is removed. This is known as elasticity of rubber.
- ▮ The type and the percentage of rubber used have a major impact on the fenders performance and longevity. It is crucial to select them correctly.
- ▮ Rubber compound is a blend of raw rubber, filler and various chemicals which improve the physical properties of weak raw rubber and protect rubber products from environmental aging.
- ▮ Raw rubber, or blend of rubbers, is the fundamental component in determining the properties of the overall rubber compound.
- ▮ Raw rubber selection and processing can optimize both the service performance and cost.
- ▮ The major cost of rubber compounds primarily comes from raw rubber and reinforcing filler called carbon black.

# Material selection for rubber fenders

## TYPE OF RUBBER

### General purpose rubber:

#### 1. Natural Rubber:

- Crude natural rubber is found in the extracts of the shrubs, vines, and trees of many plants. The principal of which is the Hevea Brasiliensis tree, native to Brazil. The latex of the natural rubber, after being processed, becomes an elastomer with excellent mechanical properties.
- Natural Rubber has a typical service temperature range between -67°F (-55°C) and 180°F (80°C).

#### 2. Synthetic Rubber: SBR

- SBR is a synthetic copolymer of styrene and butadiene rubber.
- SBR was originally developed to replace natural rubber in the production of tire. Its usage in manufacturing tires continues till today. SBR and natural rubber account for 90% of the world's rubber consumption.
- SBR has a typical service temperature range between -50°F (-45°C) and 225°F (100°C).

### Rubber blends: Natural and synthetic rubber blends

- The technology of polymer blends has developed to become an important segment of polymer science in many decades.
- Polymer blends better satisfy end-use requirements than single polymers and have become successful commercially and technically.
- It is also more economical to blend polymers to meet application requirements than to design new materials during end use.

### Special purpose rubber:

#### 1. EPDM:

- EPDM rubber (ethylene propylene diene monomer [M-class] rubber), a type of synthetic rubber, is an elastomer which is characterized by a wide range of applications.
- The E refers to ethylene, P to propylene, D to diene and M refers to its classification in ASTM standard D-1418. The M class includes rubbers having a saturated chain of the polyethylene type.
- Dienes currently used in the manufacture of EPDM rubbers are dicyclopentadiene (DCPD), ethylidene norbornene (ENB), and vinyl norbornene (VNB).
- The dienes, typically comprising from 2.5% up to 12% by weight of the composition, serve as crosslinks when curing with sulphur and resin.
- EPDM rubber has outstanding resistance to aging, weathering, ozone, oxygen and many chemicals.

# Material selection for rubber fenders

## TYPE OF RUBBER

	GENERAL PURPOSE RUBBER		SPECIAL PURPOSE RUBBER
	Natural Rubber	Synthetic Rubber	EPDM Rubber
<b>Advantages</b>	<ul style="list-style-type: none"> <li>■ Has excellent tensile, elongation, tear resistance and resilience.</li> <li>■ Exhibits excellent resistance to water and cold flow.</li> <li>■ Has low compression set and can be bonded to a wide range of materials.</li> <li>■ Has good flexing qualities at low temperatures that are better than most synthetic rubber compounds.</li> <li>■ Has superb abrasion resistance when it is compounded with carbon black.</li> </ul>	<ul style="list-style-type: none"> <li>■ Has similar properties to natural rubber, but also superior water resistance, heat resistance, abrasion resistance, low-temperature flexibility, and heat aging properties (i.e., in excess heat it hardens and becomes brittle instead of softening like natural rubber does).</li> <li>■ Can be successfully bonded to a wide range of materials.</li> </ul>	<ul style="list-style-type: none"> <li>■ Offers excellent high and low temperature stability, and superior steam and water resistance.</li> <li>■ Has dynamic and mechanical properties between Natural Rubber and Synthetic Rubber range of materials.</li> </ul>
<b>Limitations</b>	<ul style="list-style-type: none"> <li>■ Deteriorates when exposed to oils, fuels, solvents, petroleum derivatives, and hydraulic fluids.</li> <li>■ Without special additives, it has poor resistance to sunlight, oxygen, ozone, and high temperatures.</li> </ul>	<ul style="list-style-type: none"> <li>■ Has poor resistance to oils, fuels, hydraulic fluids, strong acids, greases, fat, and most hydrocarbons.</li> <li>■ Without special additives, it is vulnerable to ozone, oxygen and sunlight.</li> </ul>	<ul style="list-style-type: none"> <li>■ Is not satisfactory for use in areas where the following chemicals are stored or used: Gasoline, kerosene, oils, halogenated solvents, concentrated acids, aliphatic and aromatic hydrocarbons. When these chemicals come into contact with EPDM rubber, they can cause it to break down and in some cases, even melt.</li> </ul>



# Recycled rubbers

## What is it?

Recycled rubber is manufactured by applying heat and chemical agents to ground vulcanized waste, which may have been produced as 'scrap' either during the manufacture or recycling of rubber products.

## Classification:

There are three broad approaches to recycling post-consumer scrap. Each offers something to the rubber industry, but none is an ideal substitute for virgin polymer. The first is simple granulate, the second is reclaim and the third is post-processed granulate.

Given the cost of natural rubber and the lack of availability in some places, the use of reclaimed rubber has been increasing as an additive. However this is rarely so in the premium segment of the market or in professional mixing rooms.

## Manufacturing process:

- Reclaimed rubber is an aggressive, energy-intensive system in which rubber powder is processed with some aggressive chemicals under pressure.
- The waste products are highly polluting, which means it tends to be more common in countries where environmental regulation is either weak or poorly enforced.
- This process breaks long molecules into shorter ones and the result is often a kind of soft rubber like material.
- Depending on the pressure, temperature and chemicals, the resulting material can retain some of the properties of the original, but in the end the ability to perform is severely compromised.

## Usage in tire industry:

- Reclaimed rubber does have a place as a viscosity modifier and extrusion process improver of virgin rubber.
- It may be used in partial substitution for virgin rubber (NR/SBR) in a number of products, including tires.
- The amount of reclaimed rubber is restricted to a little quantity in radial tires because of poor flex cracking and abrasion resistance.

## Usage in fender industry:

- A higher percentage of recycled rubber blended with virgin rubber, has various performance disadvantages especially in the manufacture of marine fenders. These disadvantages can include higher hysteresis and heat build-up, poorer flex and weather resistance, greater risk of cracking and poor compression set.
- Generally, the use of recycled material in new fenders is challenged by the fact that unlike paper, metals, plastics and glass, it is not currently possible to obtain materials from scrap vulcanized product that have properties adequately similar to the original materials used in manufacturing fenders.
- Fender rubber materials are highly engineered, with specific qualities of hysteresis and other chemico-physical properties, designed to optimize long life and performance characteristics, at an affordable cost.
- Unfortunately, the products currently available using recycled materials do not provide performance-enhancing characteristics; rather the presence of recycled material tends to degrade performance. Therefore, the amount of post-consumer recycled material utilized in the final product should be limited.

## Three types of filler

Fillers are used in rubber production primarily to provide reinforcement and secondarily to reduce cost. The three types of filler are namely reinforcing fillers, semi-reinforcing fillers and inert or extending fillers.

The type, quantity, particle size and dispersion of the filler within the rubber matrix can affect the physical properties of the compound and should be selected to suit the specific project requirement.

### Reinforcing Fillers:

- Reinforcing fillers are used to enhance the stiffness (modulus) and mechanical properties of the rubber compound.
- The most common reinforcing filler used in rubber compounding is carbon black.

### Semi Reinforcing:

- Semi-reinforcing fillers provide limited enhancement of the stiffness (modulus) and mechanical properties of the rubber compound and are typically used when non-marking and/or non-black elastomeric units are required..
- The most common semi-reinforcing fillers is colloidal mineral fillers such as silica.

### Inert or extending fillers :

- Inert or extending fillers offer no reinforcing effect and are added for cost cutting.
- The most common inert or extending fillers is unprocessed calcium carbonate.
- Unprocessed calcium carbonate has a particle size of greater than 1.0um (colloidal dimension 0.1um to 1.0um) and evidently too large to achieve the desired surface area interaction and a good uniform dispersion in the compound.
- The content of inert or extending filler should be restricted to a maximum of 5% for dock fender application.
- Having too much of it will produce low quality fenders that degrades faster and struggle to meet performance requirements because they are more prone to environmental aggression.

## Types of raw rubber used for manufacturing

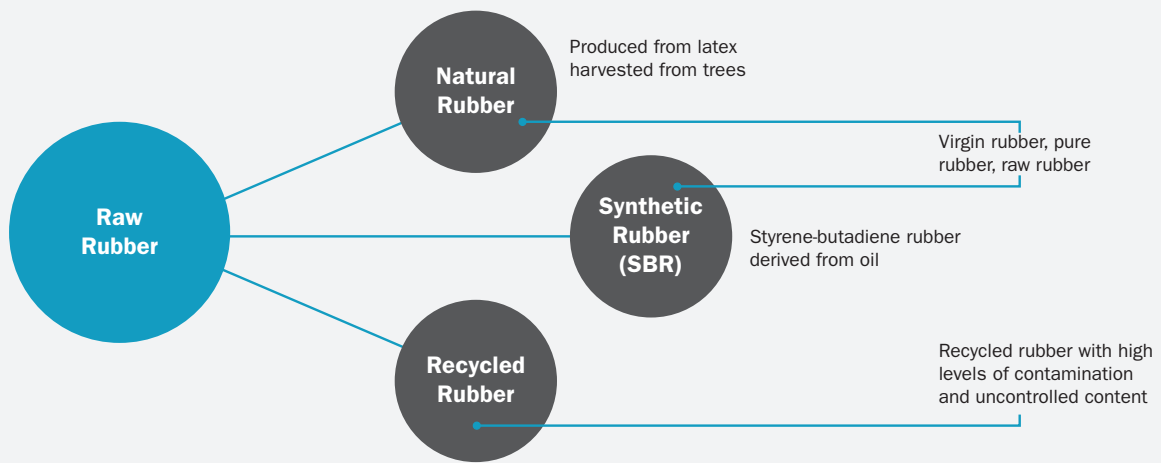

## Rubber compound

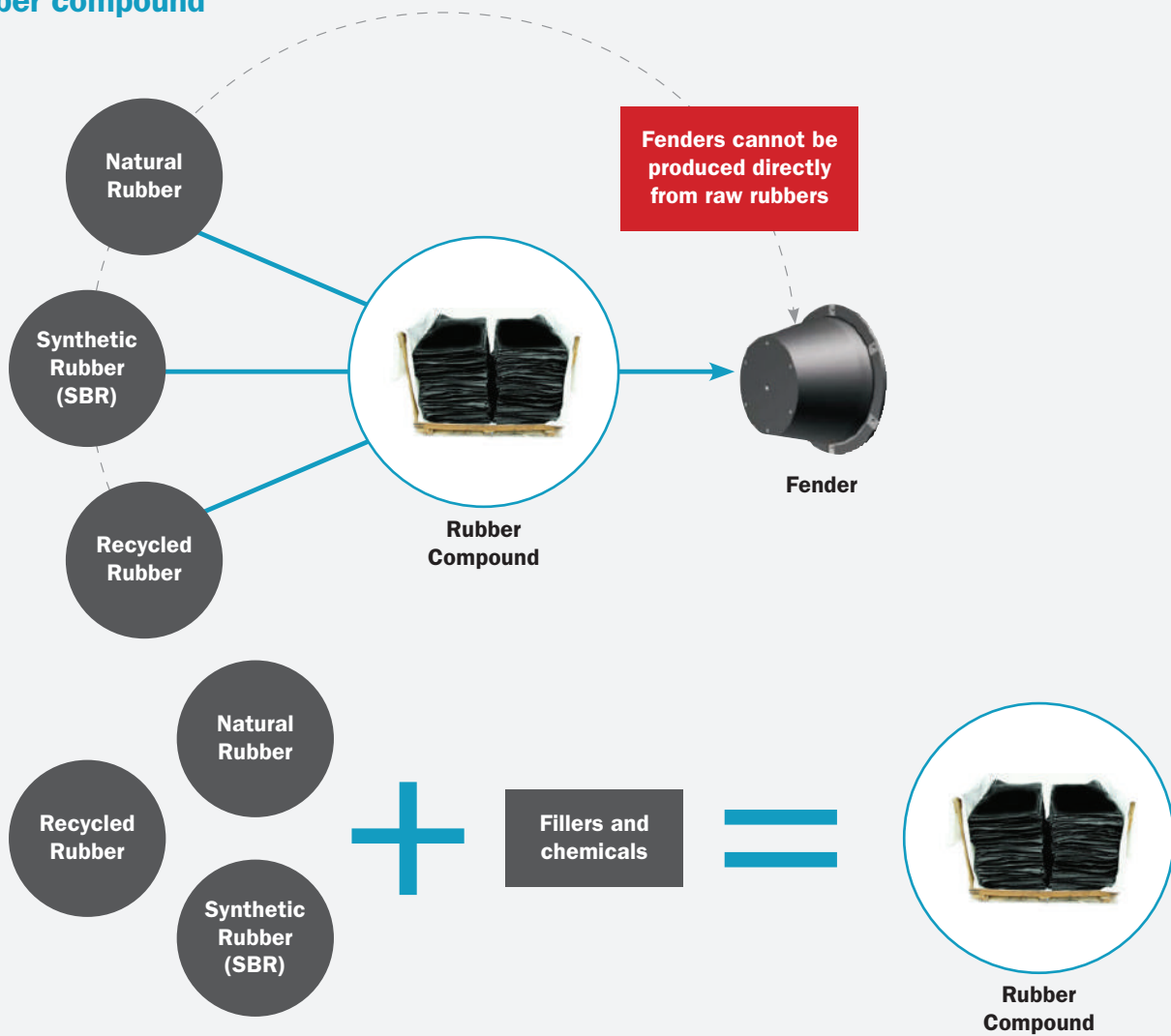

- Natural** : good mechanical properties but mechanical properties deteriorate with heat, age, oxygen, ozone
- Synthetic** : helps counter the deterioration in mechanical properties of natural rubber
- Recycled** : cost reduction, physical properties are lower than virgin rubber

# Rubber compound

It is sometimes misconstrued that a rubber compound is a single ingredient that is the same for every fender type and grade. A rubber compound can be a combination of 3 to 15 different ingredients, and thousands of different compositions can be formed by varying the percentages of different ingredients and rubber.

A typical rubber formation based on parts per

Polymer (rubber)	100 phr
Filler	20 – 40 phr
Antioxidant	1 – 3 phr
Antiozonants	1 – 3 phr
Oil	5 – 30 phr
Sulphur + accelerator	3 – 5 phr

Phr: Parts per hundred parts of rubber

In a superior compound, polymer comprises of 40-60% of its content, filler or reinforcing elements 20-40%, functional additives such as oil make up 10 – 20% and the remaining 5 -10% are other additives such as accelerators or sulphur.

## RECIPE FOR HIGH QUALITY RUBBER FENDER

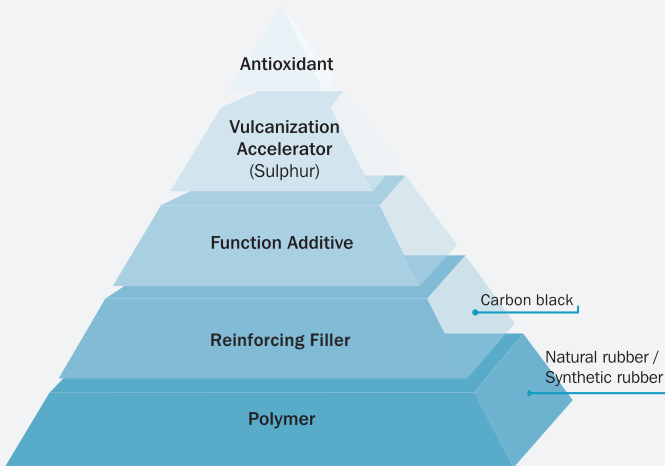

**Compounding Structure**

INGREDIENTS	%
Raw Rubber (Polymer)	40-45
Reinforcing Filler	20-40
Oil (Functional Additives)	20-10
Others (S + ACC etc)	10-5
Total	100

### Superior compounds for fenders have two basic indicators of quality:

#### 1. Rubber to filler ratio: (should be >1, for fender compounds >1.2)

- Rubber to filler ratio indicates the kg of rubber used per kg of filler in the formulation.
- Rubber to filler ratio of less than one indicates more filler than rubber in the compound. Therefore the fender compound is cheaper because the fillers are three times cheaper than virgin rubber (Natural rubber/Synthetic rubber).

#### 2. Density (ideal : close to 1, for fender <1.18)

- This is a measure of the weight per unit volume. It gives an indication of whether the correct quantities of ingredients have been added to manufacture a rubber product.
- Density of  $\text{CaCO}_3$  is 2.7 g/cc while that of Carbon black is 1.18 g/cc.
- The density of recycled rubber is 1.15 to 1.20 g/cc while that of virgin rubber is 0.92 g/cc.
- High percentage of recycled rubber and extending fillers ( $\text{CaCO}_3$ ) in the formulation is the contributing factor of density more than 1.18.

## Rubber compound

### PROPRIETARY RUBBER FORMULATION:

- | There are many ingredients that can be used which will result in different properties for a rubber compound. Rubber compounds are a combination of many different ingredients and therefore, not all compounds are the same.
- | Rubber compounding is a science which aims to assure required properties by varying the ratios of ingredients. This is why most fender manufacturers consider their rubber formulations proprietary. It can take hundreds of variations and hours of testing to perfect mechanical properties while optimizing processing.

### RUBBER COMPOUNDING – A BLACK ART

- | Designing rubber compounds used to be referred to as a black art, unpredictable due to the nature of rubber. It was difficult to predict the behavior of the products in service.
- | With many modern tools and advanced equipment at one's disposal, engineering rubber compounds for its intended purpose has become a more predictable science. Determining the chemical composition of a rubber compound is just a matter of a few chemical and analytical tests.

# Chemical composition test

## CHEMICAL COMPOSITION SPECIFICATION TABLE

- Anecdotal evidence suggests that low quality fenders degrades faster because they are more prone to environmental aggression and struggle to meet performance requirements.
- These rubber fenders in general utilize lower cost recycled rubber that has low polymer (rubber) percentage and inert or extending filler percentage in the formulation.
- Fender compounds having a density higher than 1.18 indicate a high percentage of recycled rubber and/or extending filler in its formulation. TGA and ash analysis test is a good way to find out the percentage of the inert/ extending filler.
- Historical testing requirements centered around physical properties, seen in most specifications are not enough to reflect the use of extending fillers or recycled rubber.
- The chemical composition test is useful for determining the key compositions of the rubber compound used in fenders which include:

- % Polymer:** To determine the general level of polymer present.
- % Carbon Black:** To determine the amount of reinforcing filler.
- Specific gravity:** To indicate the level of recycled rubber/ non reinforcing filler:
- % Inert or extending filler:** To determine the level of extending filler used.
- Rubber to filler ratio:** Amount of rubber compared to amount of filler

All tests give a good indication of the quality of rubber used. These parameters can be determined by using analytical techniques (FTIR/TGA) described in the following page. The specification for the indicators is given in the table below.

TEST	STANDARD	SPECIFICATION*
Density	ISO 2781	Max 1.18 g/cc
Polymer %	ASTM D6370	Min 45%
Carbon Black %	ASTM D6370	Min 20%
Inert or extending filler %	ASTM D297	Max 5%
Rubber to filler ratio	-	> 1.2

\* Not applicable to Trelleborg's standard cylindrical fender and the extruded fender but can be supplied on special request.

## TEST AVAILABLE FOR CUSTOMERS

- A lack of understanding on the rubber composition has an impact not only on the quality and performance of the fenders, but also has a downstream effect on the other wharf infrastructures.
- Until recently, buyers were unaware of the tests available to identify the composition of the rubber fenders in order to substantiate suppliers' documentation and the reported performance characteristics.

The analytical test to determine the polymer composition can be carried out on lab samples before production and by obtaining 30-50 grams of rubber from the finished products after production.

Conducting tests on the fenders is an excellent way to determine the quality of goods produced/received.

Removing just 30-50 grams of rubber from a fender body will not destroy it and will have no impact on the performance.

#### Before production:

The supplier needs to supply 2 pieces of cured tensile slabs (approximate dimension of 150 mm L x 150 mm W x 2 mm T).

Tensile slab will be sent to a third party laboratory to carry out the chemical analysis for TGA and FTIR.

The test should meet the specification given in the chemical composition specification table.

#### After production:

The client or third party will inspect the fenders and randomly select one or two for sample collection.

30-50 grams of sample will be cut from the body of the selected fender(s) and sent to a third party laboratory to test for the parameters given in the table on chemical composition specification in the previous page.

Test result should satisfy the specification. If not, more testing is needed to confirm the results and the quality of the fender(s).

## Analytical tools

### ANALYTICAL TOOLS TO DETERMINE CHEMICAL COMPOSITION:

Two most common analytical instruments to determine the chemical composition of the rubber compound are::

#### Infrared spectroscopy (FTIR)

Infrared spectroscopy (FTIR) involves passing infrared radiation onto or through a sample. The pattern of peaks and troughs in the spectra produced enables the components in the rubber compound to be identified.

#### Thermo gravimetric analysis (TGA)

Thermo gravimetric analysis (TGA) is another thermal analysis technique. It provides information complementary to FTIR.

TGA testing involves heating the test samples at different temperatures and weighing it with high precision throughout the process. Different components burnt off at different temperatures. The loss in weight provides a precise indication of the components present in the formulation.

An example of a TGA measurement of a rubber compound is shown in the following plot.

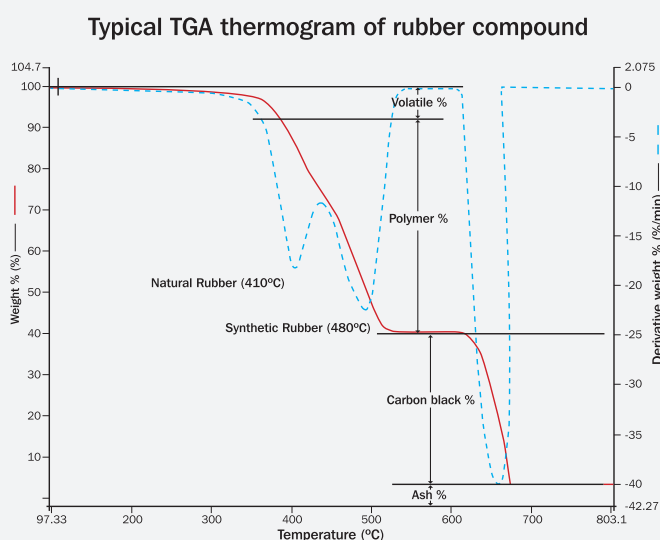

# Ensuring longevity of fender performance

## IMPORTANCE OF RUBBER COMPOUND MIXING QUALITY AND ITS IMPACT ON FENDER PERFORMANCE

- In the rubber manufacturing industry, mixing and compounding is done in batch processes using an internal mixer. This step is important because at this stage, reinforcing fillers (carbon black) are mixed with rubber.
- Filler dispersion (which is measured by a carbon black dispersion rating) in the final compound has a large impact on the quality of fender performance. A high dispersion rating is desirable for a superior rubber compound.
- A high degree of dispersion is achieved by using an internal mixer in which rotor speed/ rotor design, coolant temperature, ram pressure and fill factors are controlled. These parameters are critical in achieving a high dispersion rating, in minimum mixing time, at a low temperature.
- A “kneader” is used by some manufacturers, instead of internal mixers, to reduce the cost of mixing and, ultimately, the final product. However, critical mixing parameters are difficult to control in a low cost kneader mixer. Therefore, the mixing time taken to achieve a similar dispersion rating to that of an internal mixer is 10-15 times higher. (Typically, it will take two to five minutes for internal mixer, compared to 15-20 minutes for a kneader to achieve similar dispersion level).
- This extended mixing time generates more heat within the kneader throughout the process. Additionally, internal mixers also benefit from an efficient cooling system which controls the mixing temperature.
- This extra mixing time, along with high temperature, dissociates the carbon to carbon chains in the rubber molecule. This is important because the elasticity of the rubber molecule, its recovery after compression, tensile strength and modulus depend on the chain length (expressed by molecular weight or viscosity of the compound). Therefore, mixing compounds in a kneader carries the risk of degrading the physical properties of the rubber compound, and subsequently, the performance of the fenders.
- Compounds with different modulus (slope of stress vs. strain curve) values are used to manufacture fenders with different energy absorption grades. Soft grade fenders need compounds with lower modulus values, whereas hard grade fenders need high modulus compounds.
- The varying modulus values of the final compounds are achieved through the carbon black and oil ratios in the formula, as well as the carbon black dispersion in the rubber matrix, for a particular curing system (sulphur, accelerated ratio).
- Poor dispersion can give rise to certain detrimental effects such as:
  - Reduction of fatigue life
  - Poor performance in service
  - Poor product appearance
  - Poor product uniformity
- Trelleborg Marine and Infrastructure ensures a high quality of carbon black dispersion by properly selecting the type of carbon black, the mixing sequence and the type of mixer for rubber compound processing. This ensures the right modulus of compounds and, subsequently, a long service life fender.



## **Effectiveness of Cone and Cell Fenders in submerged water conditions**

In recent years, there has been a focus on the impact on reaction of compression of fenders under complete submergence.

Water can enter the fender slowly when it is located in a tidal zone. If a vessel is berthing during high tidal conditions and the fender is fully or partially submerged, the fender is compressed and the water inside the fender is pressurized and requires an escape route or extra space to allow the fender to compress correctly. Should the water not be able to exit the fender, or its exit flow is restricted, the fender will not be able to operate at its rated reaction since water is generally non-compressible and this could add to the fender reaction force acting on the vessel and the supporting structure.

Calculations conducted utilizing Bernoulli principles show that:

- There is the potential for a substantial increase in reaction to be generated should a fully submerged fender be subject to high velocity berthing (within normal design velocities).
- This reaction force has the potential to generate a catastrophic failure in other supplied fender components as well as potentially cause a catastrophic failure of the dolphin and wharf structures.
- Additionally, the loads onto the vessels themselves could affect structural integrity of vessels utilizing the berth.

The exit route for water on an SCN and SCK fenders is through a number of small recesses (foot slot) molded into the flanges at the end of the fender. Foot slot sizes of SCN and SCK fenders are specially determined so that there is minimal increase in force due to the fully submerged fender compression.

Some fender system designers and consultants make allowances for this volume of water by adding holes or slots to the faces of mounting panels or frontal frames directly in line with the fender's internal diameter.

# Rubber material properties

## TRELLEBORG RUBBER COMPOUND:

All Trelleborg rubber fenders are made using high quality 100% NR or 100% SBR or a blend of NR/SBR based compound which exceeds the performance requirements of international fender recommendations, such as PIANC/ EAU. Trelleborg can also manufacture fenders from materials such as Neoprene and EPDM.

The tables below give the physical properties of rubber compounds as described above which are used for making fenders. These properties are confirmed during quality assurance testing prior to fender manufacturing.

All test results are derived from test pieces made and cured in-house. Results of samples taken from actual fenders may differ due to the sample preparation process – please ask for details.

## MOLDED FENDERS:

PROPERTY	TESTING STANDARD	CONDITION	REQUIREMENT
Tensile Strength	ISO 37; ASTM D412 Die C; BS ISO 37; DIN 53504; AS 1683.11; JIS K 6251	Original	16.0 MPa (min)
		Aged for 96 hours at 70°C	12.8 MPa (min)
Elongation at Break	ISO 37; ASTM D412 Die C; BS ISO 37; DIN 53504; AS 1683.11; JIS K 6251	Original	350%
		Aged for 96 hours at 70°C	280%
Hardness	ISO 48-4; ASTM D2240; DIN ISO 7619-1; AS 1683.15.2; JIS K 6253-3	Original	78° Shore A (max)
		Aged for 96 hours at 70°C	Original +8° Shore A (max)
Compression Set	ISO 815-1; ASTM D395 Method B; BS ISO 815-1; JIS K 6262	22 hours at 70°C	30% (max)
Tear Strength	ISO 34-1; ASTM D624 Die B; AS 1683.12; JIS K 6252-1	Original	70kN/m (min)
Ozone Resistance	ISO 1431-1; ASTM D1149; BS ISO 1431-1; DIN ISO 1431-1; AS 1683-24; JIS K 6259-1	50pphm at 20% strain, 40°C, 100 hours	No cracks
Abrasion Resistance	BS 903 A9 Method B	3000 revolution	1.5cc (max)
Bond Strength	ISO 813; ASTM D429 Method B; BS ISO 813	Rubber to steel	7N/mm (min)
Seawater Resistance	ISO 1817; ASTM D471	28 days at 95°C	Hardness: ±10° Shore A (max) Volume: +10/-5% (max)
Dynamic Fatigue	ASTM D430 Method B	15,000 cycles	Grade 0–2†

† Grade 0 = No cracking has occurred

Grade 1 = Cracks at this stage appear as pin pricks to the naked eye. Grade as 1 if the pin pricks are less than 10 in number and less than 0.5 mm in length

Grade 2 = Assess as Grade 2 if either of the following applies: (1) The pin pricks are in excess of 10 in number, or (2) The number of cracks is less than 10 but one or more cracks have developed beyond the pin prick stage, that is, they have perceptible length without much depth, but their length is still less than 0.5 mm.

# Rubber material properties

## EXTRUDED AND WRAPPED FENDERS:

PROPERTY	TESTING STANDARD	CONDITION	REQUIREMENT
Tensile Strength	ISO 37; ASTM D412 Die C; BS ISO 37; DIN 53504; AS 1683.11; JIS K 6251	Original	13.0 MPa (min)
		Aged for 96 hours at 70°C	10.4 MPa (min)
Elongation at Break	ISO 37; ASTM D412 Die C; BS ISO 37; DIN 53504; AS 1683.11; JIS K 6251	Original	280% (min)
		Aged for 96 hours at 70°C	224% (min)
Hardness	ISO 48-4; ASTM D2240; DIN ISO 7619-1; AS 1683.15.2; JIS K 6253-3	Original	78° Shore A (max)
		Aged for 96 hours at 70°C	Original +8° Shore A (max)
Compression Set	ISO 815-1; ASTM D395 Method B; BS ISO 815-1; JIS K 6262	22 hours at 70°C	30% (max)
Tear Strength	ISO 34-1; ASTM D624 Die B; AS 1683.12; JIS K 6252-1	Original	60kN/m (min)
Ozone Resistance	ISO 1431-1; ASTM D1149; BS ISO 1431-1; DIN ISO 1431-1; AS 1683-24; JIS K 6259-1	50pphm at 20% strain, 40°C, 100 hours	No cracks
Abrasion Resistance	BS 903 A9 Method B	3000 revolution	1.5cc (max)
Seawater Resistance	ISO 1817; ASTM D471	28 days at 95°C	Hardness: ±10° Shore A (max) Volume: +10/-5% (max)

# Rubber material properties

## HIGH PERFORMANCE SUPER ABRASION RESISTANT FENDERS:

PROPERTY	TESTING STANDARD	CONDITION	REQUIREMENT
Tensile Strength	ISO 37; ASTM D412 Die C; BS ISO 37; DIN 53504; AS 1683.11; JIS K 6251	Original	16.0 Mpa (min)
		Aged for 96 hours at 70°C	14.4 Mpa (min)
Elongation at Break	ISO 37; ASTM D412 Die C; BS ISO 37; DIN 53504; AS 1683.11; JIS K 6251	Original	350% (min)
		Aged for 96 hours at 70°C	280% (min)
Hardness	ISO 48-4; ASTM D2240; DIN ISO 7619-1; AS 1683.15.2; JIS K 6253-3	Original	75° Shore A (max)
		Aged for 96 hours at 70°C	Original +8° Shore A (max)
Compression Set	ISO 815-1; ASTM D395 Method B; BS ISO 815-1; JIS K 6262	22 hours at 70°C	30% (max)
Tear Strength	ISO 34-1, ASTM D624 Die B; AS 1683.12; JIS K 6252-1	Original	70 kN/m (min)
Ozone Resistance	ISO 1431-1; ASTM D1149; BS ISO 1431-1; DIN ISO 1431-1; AS 1683-24; JIS K 6259-1	50 pphm at 20% strain, 40°C, 100 hours	No cracks
Abrasion Resistance	BS 903 A9 Method B	3000 revolution	0.5 cc (max)
Seawater Resistance	ISO 1817; ASTM D471	28 days at 95°C	Hardness: ±10° Shore A (max) Volume: +10/-5% (max)

## Tolerances

Trelleborg fenders are subjected to standard manufacturing and performance tolerances.

For specific applications, smaller tolerances may be agreed on a case-by-case basis.

FENDER TYPE	DIMENSION	TOLERANCE	
Molded fenders	All dimensions	±3% or ±2 mm*	
	Bolt hole spacing	±4 mm (non-cumulative)	
Composite fenders	Cross-section	±3% or ±2 mm*	
	Length	±2% or ±25 mm*	
	Drilled hole centers	±4 mm (non-cumulative)	
	Counterbore depth	±2 mm (under-head depth)	
Keyhole fenders / M fenders / W fenders	Cross-section	±2% or ±2 mm*	
	Length	±2% or ±10 mm*	
	Fixing hole centers	±3 mm	
	Fixing hole diameter	±3 mm	
Cylindrical fenders	Outside diameter	±4%	
	Inside diameter	±4%	
	Length	±30 mm	
Extruded fenders	Cross-section	±4% or ISO 3302-E3*	
	Length	±30 mm	
	Drilled hole centers	±4 mm (non-cumulative)	
	Counterbore depth	±3 mm (under-head depth)	
HD-PE sliding fenders† / UHMW-PE face pads†	Length and width	±5 mm (cut pads)	
	Length and width	±20 mm (uncut sheets)	
	Thickness (planed) :	≤ 30 mm	±0.2 mm
		31 – 100 mm	±0.3 mm
		≥ 101 mm	±0.5 mm
	Thickness (unplaned) :	≤ 30 mm	±2.5 mm
		31 – 100 mm	±4.0 mm
		≥ 101 mm	±6.0 mm
	Drilled hole centers	±2 mm (non-cumulative)	
	Counterbore depth	±2 mm (under-head depth)	

\* Whichever is the greater dimension

† HD-PE and UHMW-PE dimensions are measured at 18°C and are subject to thermal expansion coefficients (see material properties)

## Performance tolerances<sup>^</sup>

FENDER TYPE	PARAMETER	TOLERANCE
SCN, SCK, UE, AN, ANP, SAN, SANP, MV and MI fenders	Reaction, energy	±10%
Cylindricals (wrapped)	Reaction, energy	±10%
Extruded fenders	Reaction, energy	±20%
Foam fenders	Reaction, energy	±10%
Pneumatic fenders	Reaction, energy	±10%
Keyhole, composite, M, W, tug and workboat fenders	Reaction, energy	±20%

<sup>^</sup> Performance tolerances apply to Constant Velocity (CV) and Rated Performance. They do not apply to energy and/or reaction at intermediate deflections. The nominal rated deflection may vary when CV performance is achieved and is provided for guidance only. Please consult Trelleborg Marine and Infrastructure for performance tolerance on fender types not listed above.

# Frequently asked questions

## VELOCITY FACTOR (VF) / TEMPERATURE FACTOR (TF)

Q: Is it important to consider VF & TF during the design of fender systems?

A: Yes, it is. Without considering the effects of VF & TF, designers may either over-design or under-design the fender system

Q: Does 'PIANC' suggest applying VF & TF for designing the fender systems?

A: Yes, PIANC's "Guidelines for the Design of Fenders Systems: 2002" highlighted the importance of VF & TF in the design & selection of fenders. It also provides technical guidelines for reporting & calculating of VF & TF.

Q: At what velocity are fenders usually tested in the manufacturer's testing facilities?

A: Testing is usually conducted at 2 - 8 cm/min compression speed, and the performance data is usually reported at 2 - 8 cm/min speed.

Q: Do you expect the fender performance to differ from the test performance at normal berthing velocities of vessels?

A: According to the theory of polymer Rheology, the stress or reaction force produced by a rubber fender during compression depends on the strain level and strain rate. When a fender is compressed, the resultant reaction force and energy absorption are greater at high compression velocities.

Hence, at normal berthing velocities (20 mm/s-500 mm/s), the performance is expected to be different from the performance tested at 2 - 8 cm/min velocity.

Q: It seems fender performance depends on the velocity of testing. At what test velocity should fenders be tested?

A: Fenders should ideally be tested at the maximum design berthing speed to determine its actual performance.

Q: Why are fenders not tested at high velocities or real life berthing speed?

A: Due to the lack of high velocity test equipment/facilities, full size fenders are usually tested at 2 - 8 cm/min compression speed.

Q: How do we reconcile the difference in performances between 2 - 8 cm/min test velocity and real life berthing velocities?

A: PIANC suggests applying VF to account for the performance difference between testing velocity & real life berthing velocity. 2 - 8 cm/min test performance needs to be multiplied by VF to calculate the performance of the fender at real life berthing velocity.

Q: Who provides the VF values?

A: Only fender manufacturers can supply VF. VF values are generated through a series of experiments using smaller commercial size fenders tested at high velocities.

Q: What factors influence VF?

A: For a given velocity there are two factors that have the greatest influence on VF: strain rate & rubber compound formulation.

Q: What is strain rate?

A: In simple term, strain rate means how quickly the fender is being compressed. Compression time is an indirect measure of strain for a given velocity. A larger fender needs more time to be compressed than a smaller one. Subsequently at the same berthing velocity, the strain rate of a larger fender and the magnitude of the VF will be lower than a smaller fender.

# Frequently asked questions

## VELOCITY FACTOR (VF) / TEMPERATURE FACTOR (TF)

Q: How does the composition of rubber influence VF?

A: The magnitude of VF is greatly influenced by the type of rubber used in compound formulation. A fender comprising of 100% natural rubber (NR) will have a lower velocity factor than a fender comprised of a blend of natural and synthetic rubber or 100% synthetic rubber, due to the differences in the microstructure of the rubber and the rate of stress relaxation for different rubber and its blend.

Q: What is the effect of VF on the design of a fender system?

A: Using VF, fender performance figures should be adjusted to account for design berthing velocity. Design of the fender system will need to account for the increase reaction force in relation to restraint chain and fixing anchor design as well as forces applied to the frontal frames. In addition, the increased reaction force will need to be reviewed against the structural design of the wharf (quay wall or dolphin, etc).

Q: Is VF dependent on the geometry of the fender?

A: No, VF depends on the height of the fender. Taller fenders will have a smaller VF in comparison to shorter fenders.

Q: Will softer and harder fenders have different VF?

A: Yes, but the difference is not significant. The compound composition has a greater effect on VF than fender geometry or rubber hardness.

Q: Can I use the same VF for fenders purchased from different suppliers?

A: As the chemical composition of the rubber compound is different for different manufacturers, the same VF cannot be applied on different fender suppliers.

Q: What do I need to calculate VF?

A: We need to know two parameters to calculate VF. We must know the rated deflection for the selected fender and initial berthing velocity. The compression time

$$t = \frac{\text{Rated Deflection}}{\text{Initial berthing velocity} \times \text{Decelerating factor}}$$

(refer to page 35)

can be calculated using these two parameters. Design speed needs to be corrected by a factor to account for the real life deceleration effect during berthing before calculating compression time using the above formula. Fender manufacturer must then provide the VF value against the compression time.

Q: What is the usual temperature at which fenders are tested?

A: PIANC's "Guidelines for the Design of Fenders Systems: 2002" recommends testing at a temperature of  $23 \pm 5^\circ\text{C}$ .

Q: In real life fenders are used at different temperatures in different parts of the world. Does the difference in test temperature have an effect on the performance of the fender?

A: The stiffness of the rubber compound usually goes up at low temperature and goes down at high temperature. Hence, the performance of fenders is expected to vary if the usage temperature is different from the testing temperature.

Q: What is stiffness & why is it important for rubber fenders?

A: Elasticity of rubber is measured by stress & strain behavior and expressed in terms of modulus or stiffness of the rubber compound. Elasticity is a measure of rubber rigidity. Reaction force and thus energy absorption are directly proportional to rubber rigidity. Rigidity changes drastically with temperature which in turn has a tremendous effect on the fender performance.

# Frequently asked questions

## VELOCITY FACTOR (VF) / TEMPERATURE FACTOR (TF)

Q: How do we reconcile the differences in performance of fenders at actual operating temperature and testing temperature?

A: It is essential to apply TF during the fender design and selection process based on the recommendations by PIANC's "Guidelines for the Design of Fenders Systems: to accommodate the variations in temperature that the fenders will be exposed to under actual operating conditions.

Q: What are the factors that impact the magnitude of TF?

A: Similar to VF, TF is highly sensitive to the type of rubber used in the compound formulation, i.e. use of natural rubber or synthetic rubber or a blend of natural and synthetic rubber.

Q: Does TF depend on strain rate?

A: No, strain rate does not affect TF.

Q: Does TF depend on the geometry of fenders?

A: No, TF is mainly dependent on the chemical composition of rubber compound.

Q: Does TF vary with rubber hardness and across manufacturers?

A: Different manufacturers use different rubber formulations to produce fenders. Hence, TF will vary depending on the type & percentage of rubber ingredients used in the composition.

Q: How do designers calculate TF?

A: Designers calculate TF based on the knowledge of fender application temperature and the TF provided by the manufacturer.

Q: Should designers apply VF & TF simultaneously or separately?

A: VF & TF must be applied together to calculate the final performance data.

Q: What is the expected life expectancy of a rubber fender?

A: The life expectancy of a fender system is highly dependent on the critical rubber component and other accessories. The durability and subsequent life cycle of rubber fenders depend on many factors, like the type of rubber used, compound formulation, environmental conditions in situ, ozone & operational use and mechanical damage. Well formulated (virgin rubber rich) fender is expected to last for more than 10 to 15 years or even more.

Q: Does temperature have an effect on the longevity of rubber fenders?

A: Oxidative aging, a chemical process described as the change in rubber properties over time, is one of the main issues impairing the functionality of rubber fenders over their lifecycle. The reaction rate of chemical process increases with temperature. Hence, temperature is one of the important parameters that determine the life of a fender.

Q: Does rubber composition affect the life of a fender?

A: It has been experimentally proven that fender compound samples made of higher percentage of recycled rubber (often used to reduce the cost of the fender) have a significantly shorter service life. Oxidative aging process is much faster for recycled rubber. The selection of compound ingredient is the most critical aspect in ensuring longevity of the fender, especially in environments with adverse operating conditions.

Q: It seems that rubber compound composition is a valuable knowledge for a fender designer or purchaser. Is there any way to find out the rubber composition from the finished product?

A: Yes, analytical techniques are available to identify the rubber composition of fender, making it possible to accurately determine the presence of ingredients that are critical to the life of the fender. Moreover, only a little sample is required to carry out the test at a 3rd party standard rubber laboratory, without destroying the full fender. (refer to page 72)





AUSTRALIA

# Glossary

## COMMONLY USED SYMBOLS

SYMBOL	DEFINITION	UNITS
B	Beam of vessel (excluding beltings and strakes)	m
C	Positive clearance between hull of vessel and face of structure	m
$C_B$	Block coefficient of vessel's hull	–
$C_C$	Berth configuration coefficient	–
$C_E$	Eccentricity coefficient	–
$C_M$	Added mass coefficient (virtual mass coefficient)	–
$C_S$	Softness coefficient	–
D	Draft of vessel	m
$E_N$	Normal berthing energy to be absorbed by the fender	kNm
$E_A$	Abnormal berthing energy to be absorbed by the fender	kNm
$F_c$	Factor of safety for chains	2~3
$F_L$	Freeboard at laden draft	m
$F_S$	Abnormal impact safety factor	–
h	Fender projection when compressed, measured at centerline of the fender	–
H	Height of compressible part of the fender	m
$H_1$	Static offset between brackets	m
$H_2$	Dynamic offset between brackets at F	m
$H_b$	Belting height	mm
K	Radius of gyration of vessel	m
$K_C$	Under keel clearance	m
$L_C$	Bearing length of chain	m
$L_{OA}$	Overall length of vessel's hull	m
$L_{BP}$	Length of vessel's hull between perpendiculars	m
$L_S$	Overall length of the smallest vessel using the berth	m
$L_L$	Overall length of the largest vessel using the berth	m
$M_D$	Displacement of vessel	tonne
n	Number of chains acting together	–
P	Fender pitch or spacing	m

# Glossary

## COMMONLY USED SYMBOLS

SYMBOL	DEFINITION	UNITS
R	Distance from point of contact to the center of mass of the vessel	m
$R_B$	Vessel bow radius	m
$R_F$	Reaction force of the fender	kN
V	Velocity of the vessel (true vector)	m/s
$V_B$	Approach velocity of the vessel perpendicular to the berthing line	m/s
$V_L$	Longitudinal velocity component (forward or astern)	m/s
$\alpha$	Berthing angle	degree
$\beta$	Bow flare angle	degree
$\delta_F$	Deflection of the fender unit	% or m
$\theta$	Hull contact angle with fender	degree
$\rho_{SW}$	Seawater density	t/m <sup>3</sup>
$\mu$	Coefficient of friction	–
$\phi$	Velocity vector angle (between $V_B$ and R)	degree
$\phi_1$	Static angle of chain	degree
$\phi_2$	Dynamic angle of chain	degree
$\Sigma R$	Combined reaction of all rubber fenders	kN
LWT	Light Weight Tonnage	tonne
DWT	Dead Weight Tonnage	tonne
SWL	Safe Working Load of chain	tonne
MBL	Minimum Breaking Load of chain	tonne
TEU	Twenty-foot Equivalent Units, different shipping companies may use different definitions for estimations of overall TEU capacity	tonne
CEU	Car Equivalent Units	tonne

## Codes and guidelines

Codes	Description
ROM 2.0-11	Actions in the Design of Maritime and Harbor Works
ROM 3.1	Actions in the Design of Maritime and Harbor Works : this is the latest version of the Spanish ROM available in English
BS6349-4:2014	Code of Practice for Design of Fendering and Mooring Systems
EAU 2004	Recommendations of the Committee for Waterfront Structures
PIANC 2002	Guidelines for the Design of Fender Systems: 2002 Marcom Report of WG33
ISO EN 12944	Standard for Corrosion protection of steel structures by protective paint systems
ASTM	An international standards organization that develops and publishes voluntary consensus technical standards for a wide range of materials, products, systems, and services
EN 10025	A set of European standards which specify the technical delivery conditions for hot rolled products of structural steels
JIS G-3101	A Japanese material standard for hot rolled steel plates, sheets, strips for general structural usage
PIANC report WG121	Harbor approach changes design guidelines from 2014 including the latest design information on vessels

## **DISCLAIMER**

Trelleborg AB has made every effort to ensure that the technical specifications and product descriptions in this manual are correct.

The responsibility or liability for errors and omissions cannot be accepted for any reason whatsoever. Customers are advised to request a detailed specification and certified drawing prior to construction and manufacture. In the interests of improving the quality and performance of our products and systems, we reserve the right to make specification changes without prior notice. All dimensions, material properties and performance values quoted are subject to normal production and testing tolerances. This manual supersedes the information provided in all previous editions. If in doubt, please check with Trelleborg Marine and Infrastructure.

© Trelleborg AB, PO Box 153, 231 22 Trelleborg, Sweden.

This manual is the copyright of Trelleborg AB and may not be reproduced, copied or distributed to third parties without the prior consent of Trelleborg AB in each case.



Trelleborg is a world leader in engineered polymer solutions that seal, damp and protect critical applications in demanding environments. Its innovative solutions accelerate performance for customers in a sustainable way.

[WWW.TRELLEBORG.COM/MARINEANDINFRASTRUCTURE](http://WWW.TRELLEBORG.COM/MARINEANDINFRASTRUCTURE)



facebook: [TrelleborgMarineandInfrastructure](https://www.facebook.com/TrelleborgMarineandInfrastructure)  
twitter: [@TrelleborgMI](https://twitter.com/TrelleborgMI)  
[youtube.com/c/TrelleborgMarineInfrastructure](https://www.youtube.com/c/TrelleborgMarineInfrastructure)  
[flickr.com/people/marineandinfrastructure](https://www.flickr.com/people/marineandinfrastructure)  
[linkedin.com/company/trelleborg-marine-and-infrastructure](https://www.linkedin.com/company/trelleborg-marine-and-infrastructure)  
[TheSmarterApproachBlog.trelleborg.com](http://TheSmarterApproachBlog.trelleborg.com)