

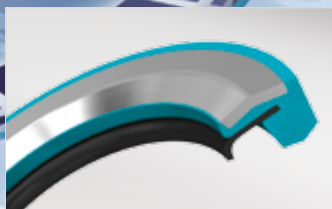

Turcon[®] Roto L

ENERGY SAVING WITH NO FRICTION



SAVING ENERGY AND FUEL

Trelleborg Sealing Solutions is a major supplier of seals to axle manufacturers for agricultural and off-highway vehicles, as well as cars, trucks and high performance vehicles. The new Turcon® Roto L seal is engineered to extend seal life on axle systems. Uniquely, it only seals when sealing is required. This reduces friction, lowering fuel consumption and thereby conserves energy.

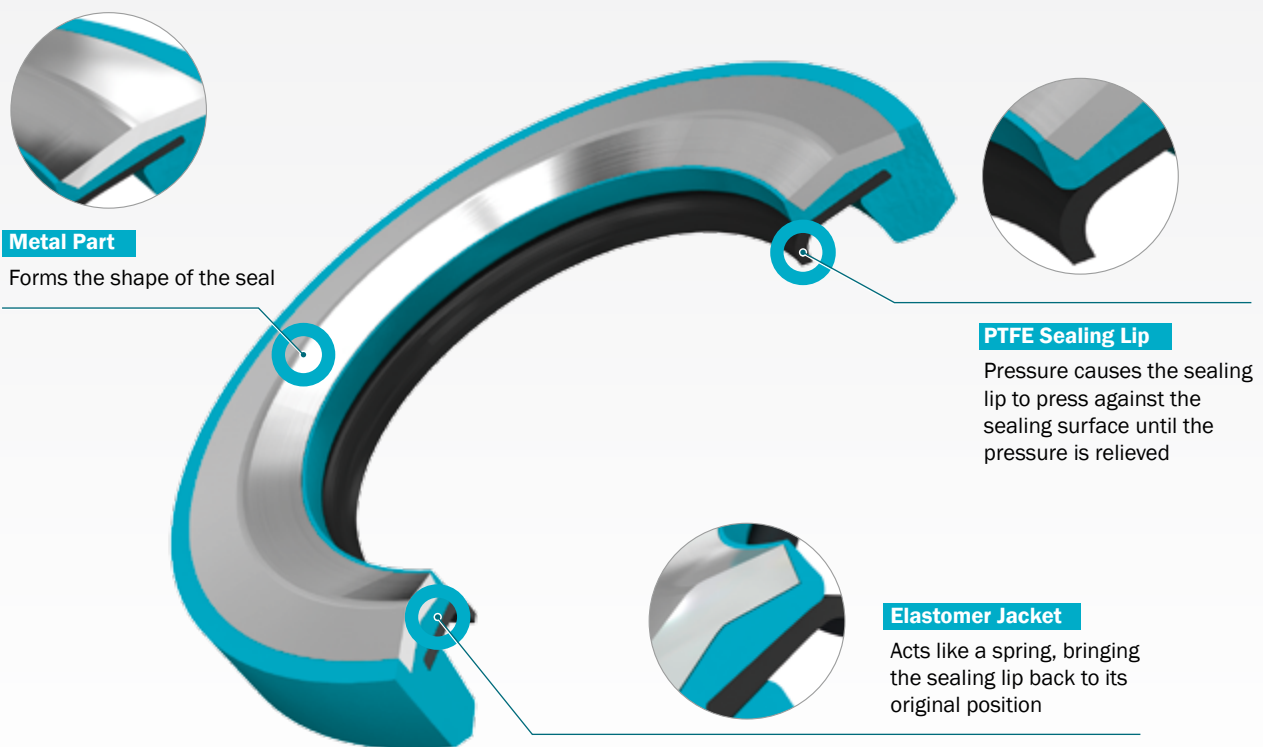

Innovative sealing concept

Turcon® Roto L combines a polytetrafluoroethylene (PTFE) sealing lip with a rubber jacket and a stable shape forming metal part.

The seal's patented design means that for the majority of the time the sealing lip is just held against the sealing surface. Its patented design offers features and benefits that no other seal can.

Features and benefits:

- Extended seal life
- Operates only when required
- Total system life sealing
- Eliminates friction when not pressurized
- Saves energy
- Improved safety
- Significant fuel savings for vehicle operators
- Deflation and inflation of tires on the move minimizes down time
- Lower overall vehicle operator costs

SAVING FUEL BY SEALING ONLY WHEN NEEDED

Turcon® Roto L is the first ever active seal, engineered to only provide sealing when it is needed for example in tire inflation systems. Eliminating friction and torque, this extends seal life and most importantly reduces fuel consumption.



Turcon® Roto L with pressure

The seal is only activated when the system is pressurized. The pressure causes the sealing lip to press against the sealing surface until the pressure is relieved.

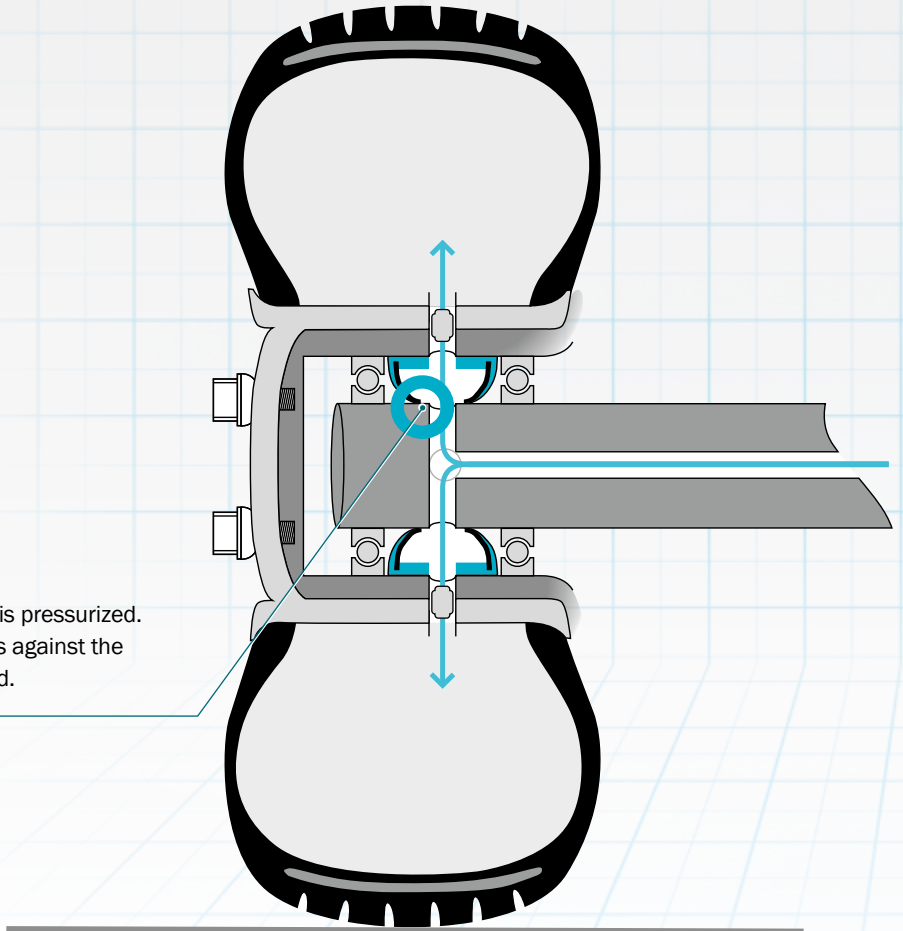

Dry air torque test

To simulate the active function of the Turcon® Roto L, in an endurance test we measured the friction of four Turcon® Roto L seals at 7 bar pressure and 0 bar pressure. In the graph we recorded the activity of the Turcon® Roto L seal, torque over time.

The nearly zero friction at 0 bar pressure and extremely low friction under pressure load are superior features of the Turcon® Roto L seal. This opens up the possibility of using the seal over the lifetime of central tire inflation systems in off-highway vehicles, trucks and sports cars.

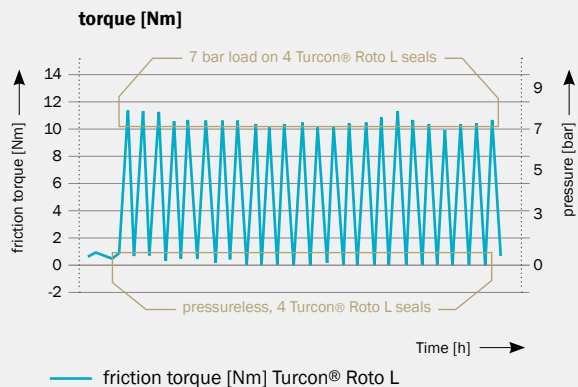



To design a solution for your specific needs contact your local **Trelleborg Sealing Solutions** marketing company.

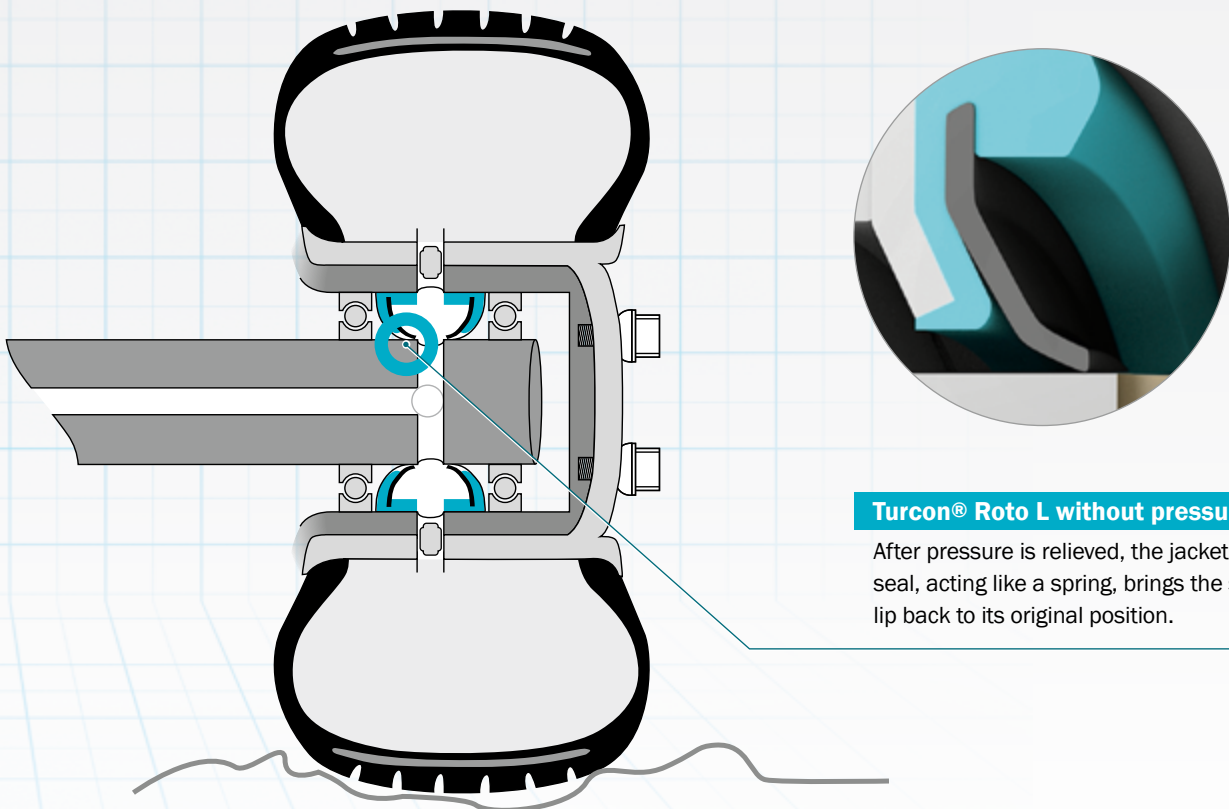

Turcon® Roto L without pressure

After pressure is relieved, the jacket of the seal, acting like a spring, brings the sealing lip back to its original position.

Lifetime of the hardware

Turcon® Roto L reduces the shaft run-in significantly. This is due to the material properties of the Turcon® M12 and Turcon® M83 sealing lip and the fact there is almost no friction when the seal is not activated.

A standard central tire inflation system seal has a run in of 10.1 μm after 168 h. In comparison, the Turcon® Roto L has a run in of 4.59 μm after 780 h. This results in a seal life that is at least four times longer.

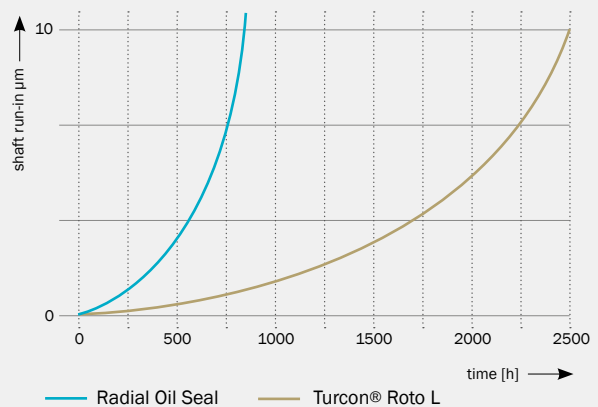

PROVIDING UNIQUE BENEFITS WHEN SEALING AXLE SYSTEMS

SEGMENT

APPLICATION

Off-highway vehicles



Off-highway tires incorporate a central tire inflation system. Their pressure is increased or decreased depending on the surface the vehicle is travelling on or the field it is working in. Sealing around the axle is only required when the tire is pressurized to inflate or deflate it. Turcon® Roto L seals only when needed, lengthening seal life and lowering fuel consumption.

Long-based trucks and multi-trailer trucks



With Turcon® Roto L, tire pressures can be optimized to road and load conditions in long-based or multi-trailer trucks. This improves traction and safety and can result in considerable fuel savings for transport companies.

Super sports cars



When super sports cars drive slowly, the tires should be kept at low pressure for driver comfort. At high speeds the cars will be safer if the tire is at high pressure, or pressure is different on each wheel, depending on the track it is travelling on. Turcon® Roto L will facilitate this pressure variation.

Lowering down time – a major cost saving

When pressurized, Turcon® Roto L has less than half the friction of the standard sealing solutions on axle systems, vehicle operators can deflate and inflate tires when the vehicle is on the move.

This is a major advantage to vehicle operators and can lead to significantly lower operating costs. It can take between 20 and 30 minutes to adjust the pressure on a large commercial tire. If this can be done while the vehicle is moving between jobs, that's up to 30 minutes that the commercial vehicle can be working rather than idle.

Turcon® Roto L advantages:

- Low friction
- Compatible with all types of hydraulic fluid
- Capable of constant activation
- High wear resistance
- Operates under high pressure
- Extended seal life reduces maintenance
- 24-7 operation

Trelleborg is a world leader in engineered polymer solutions that seal, damp and protect critical applications in demanding environments. Its innovative solutions accelerate performance for customers in a sustainable way.

Trelleborg Sealing Solutions is a leading developer, manufacturer and supplier of precision seals, bearings and custom-molded polymer components. It focuses on meeting the most demanding needs of aerospace, automotive and general industrial customers with innovative solutions.

WWW.TSS.TRELLEBORG.COM



facebook.com/TrelleborgSealingSolutions
twitter.com/TrelleborgSeals
youtube.com/TrelleborgSeals
linkedin.com/company/trelleborg-sealing-solutions